



RXT / BXV / CXT

Rotary Tillers

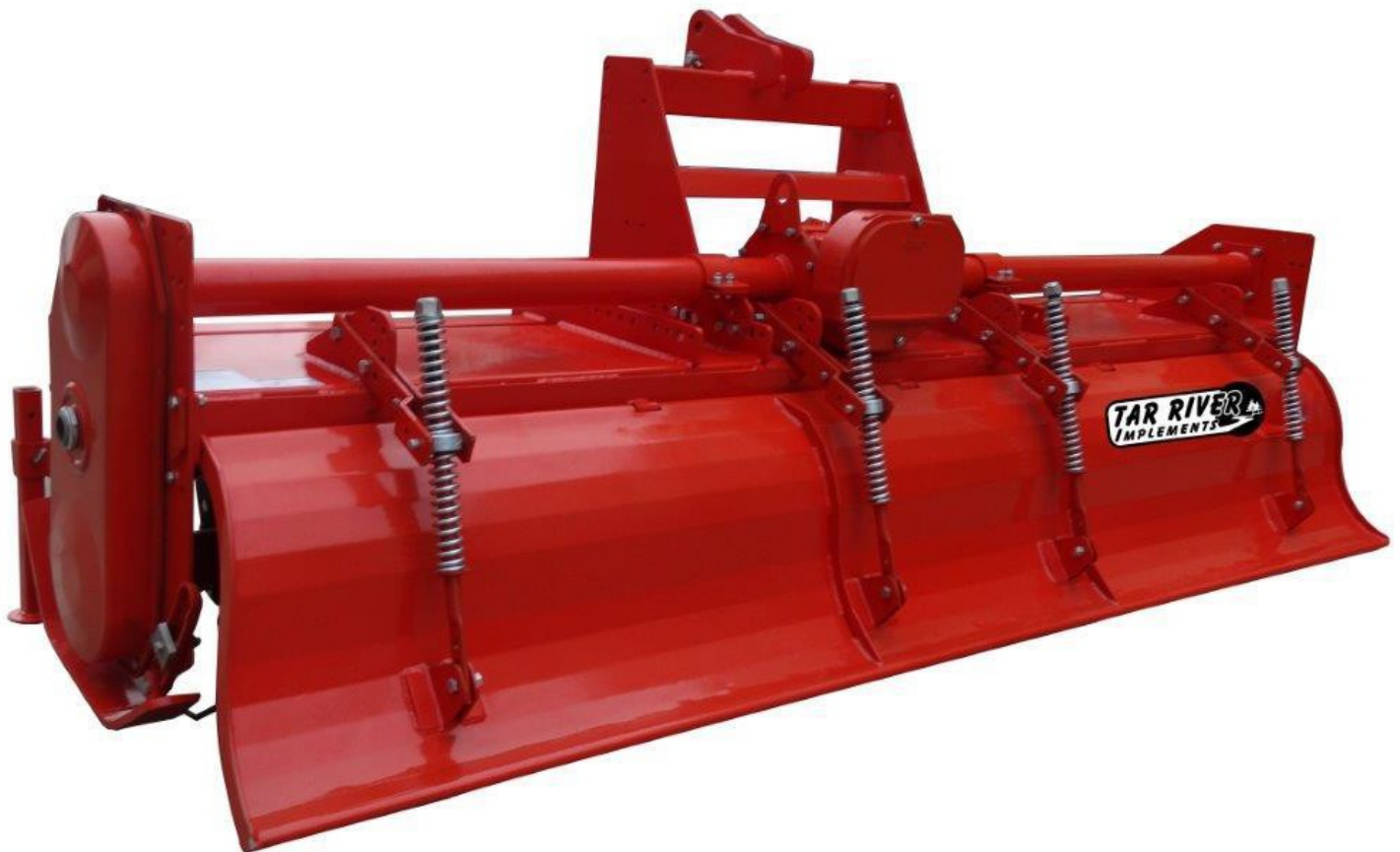

TABLE OF CONTENTS

INTRODUCTION	2
SAFETY	2
SAFETY SIGNAL WORDS	3
GENERAL SAFETY GUIDELINES	3
SAFETY DECAL CARE.....	4
BEFORE OPERATION.....	4
DURING OPERATION	5
HIGHWAY AND TRANSPORT OPERATIONS	6
OPERATION	8
FOLLOWING OPERATION	10
PREMORMING MAINTENANCE	10
MAINTENANCE	11
PARTS BREAKDOWN - RXT	12-27
PARTS BREAKDOWN - BXV.....	29-36
PARTS BREAKDOWN - CXT(VERSION 1).....	37-44
PARTS BREAKDOWN - CXT(VERSION 2)	45-52
PTO BREAKDOWN	53
LIMITED WARRANTY	55

INTRODUCTION

Thank you for purchasing your Tar River Tiller. Your rotary tiller is design to be used on 540 rpm tractors. It is important to properly maintain and keep in place all safety guards and shields that came with your tiller.

SAFETY

Read and understand this manual and all safety signs before operating and maintaining. Review the safety instructions and precautions annually.

TAKE NOTE! THIS SAFETY ALERT SYMBOL FOUND THROUGHOUT THIS MANUAL IS USED TO CALL YOUR ATTENTION TO INSTRUCTIONS INVOLVING YOUR PERSONAL SAFETY AND THE SAFETY OF OTHERS. FAILURE TO FOLLOW THESE INSTRUCTIONS CAN RESULT IN INJURY OR DEATH.



THIS SYMBOL MEANS

**ATTENTION!
BECOME ALERT!
YOUR SAFETY IS INVOLVED!**



SAFETY SIGNAL WORDS

Note the use of the signal words DANGER, WARNING and CAUTION with the safety messages. The appropriate signal word for each has been selected using the following guidelines:



DANGER: Indicates an imminently hazardous situation that, if not avoided, will result in death or serious injury. This signal word is to be limited to the most extreme situations typically for machine components which, for functional purposes, cannot be guarded.



WARNING: Indicates a potentially hazardous situation that, if not avoided, could result in death or serious injury, and includes hazards that are exposed when guards are removed. It may also be used to alert against unsafe practices.

CAUTION: Indicates a potentially hazardous situation that, if not avoided, may result in minor or moderate injury. It may also be used to alert against unsafe practices.



GENERAL SAFETY GUIDELINES

Safety of the operator is one of the main concerns in designing and developing a new piece of equipment. Designers and manufacturers build in as many safety features as possible. However, every year many accidents occur which could have been avoided by a few seconds of thought and a more careful approach to handling equipment. You, the operator, can avoid many accidents by observing the following precautions in this section. To avoid personal injury, study the following precautions and insist those working with you, or for you, follow them.

Replace any CAUTION, WARNING, DANGER or instruction safety decal that is not readable or is missing. Location of such decals is indicated in this booklet.

Do not attempt to operate this equipment under the influence of drugs or alcohol.

Review the safety instructions with all users annually.

This equipment is dangerous to children and persons unfamiliar with its operation. The operator should be a responsible adult familiar with farm machinery and trained in this equipment's operations. **Do not allow persons to operate or assemble this unit until they have read this manual and have developed a thorough understanding of the safety precautions and of how it works.**

To prevent injury or death, use a tractor equipped with a Roll Over Protective System (ROPS). Do not paint over, remove or deface any safety signs or warning decals on your equipment. Observe all safety signs and practice the instructions on them.

Never exceed the limits of a piece of machinery. If its ability to do a job, or to do so safely, is in question - **DON'T TRY IT.**



SAFETY DECAL CARE

- Keep safety signs clean and legible at all times.
- Replace safety signs that are missing or have become illegible.
- Replaced parts that displayed a safety sign should also display the current sign.
- Safety signs are available from your Distributor or Dealer Parts Department or the factory.

How to Install Safety Signs:

- Be sure that the installation area is clean and dry.
- Decide on the exact position before you remove the backing paper.
- Remove the smallest portion of the split backing paper.
- Align the decal over the specified area and carefully press the small portion with the exposed sticky backing in place.
- Slowly peel back the remaining paper and carefully smooth the remaining portion of the decal in place.
- Small air pockets can be pierced with a pin and smoothed out using the piece of decal backing paper.



BEFORE OPERATION

- Carefully study and understand this manual.
- Do not wear loose-fitting clothing, which may catch in moving parts.
- Always wear protective clothing and substantial shoes.
- Assure that all tires are inflated evenly.
- Give the unit a visual inspection for any loose bolts, worn parts or cracked welds, and make necessary repairs. Follow the maintenance safety instructions included in this manual.
- Be sure that there are no tools lying on or in the equipment.
- Do not use the unit until you are sure that the area is clear, especially children and animals.

- Don't hurry the learning process or take the unit for granted. Ease into it and become familiar with your new equipment.
- Practice operation of your equipment and its attachments. Completely familiarize yourself and other operators with its operation before using.
- Use a tractor equipped with a Roll Over Protective System (ROPS) and fasten your seat belt prior to starting the engine.
- The manufacturer does not recommend usage of tractor with ROPS removed.
- Move tractor wheels to the widest recommended settings to increase stability.
- Securely attach to towing unit. Use a high strength, appropriately sized hitch pin with a mechanical retainer and attach safety chain.
- Do not allow anyone to stand between the tongue or hitch and the towing vehicle when backing up to the equipment.



DURING OPERATION

- Children should not be allowed on the product.
- Clear the area of small children and bystanders before moving the feeder.
- If using a towing unit, securely attach feeder by using a hardened 3/4" pin, a metal retainer, and safety chains if required. Shift towing unit to a lower gear before going down steep downgrades, thus using the engine as a retarding force. Keep towing vehicle in gear at all times. Slow down for corners and rough terrain.
- Make sure you are in compliance with all local and state regulations regarding transporting equipment on public roads and highways. Lights and slow moving signs must be clean and visible by overtaking or oncoming traffic when feeder is transported.
- Beware of bystanders, **particularly children!** Always look around to make sure that it is safe to start the engine of the towing vehicle or move the unit. This is particularly important with higher noise levels and quiet cabs, as you may not hear people shouting.
- **NO PASSENGERS ALLOWED** - Do not carry passengers anywhere on, or in, the tractor or equipment, except as required for operation.
- Keep hands and clothing clear of moving parts.
- Do not clean, lubricate or adjust your equipment while it is moving.
- When halting operation, even periodically, set the tractor or towing vehicle brakes, disengage the PTO, shut off the engine and **remove the ignition key.**
- Be especially observant of the operating area and terrain - watch for holes, rocks or other hidden hazards. Always inspect the area prior to operation.

- **DO NOT** operate near the edge of drop-offs or banks.
- **DO NOT** operate on steep slopes as overturn may result.
- Operate up and down (not across) intermediate slopes. Avoid sudden starts and stops.



HIGHWAY AND TRANSPORT OPERATIONS

- Adopt safe driving practices:
- Keep the brake pedals latched together at all times. **NEVER USE INDEPENDENT BRAKING WITH MACHINE IN TOW AS LOSS OF CONTROL AND/OR UPSET OF UNIT CAN RESULT.**
- Always drive at a safe speed relative to local conditions and ensure that your speed is low enough for an emergency stop to be safe and secure. Keep speed to a minimum.
- Reduce speed prior to turns to avoid the risk of overturning.
- Avoid sudden uphill turns on steep slopes.
- Always keep the tractor or towing vehicle in gear to provide engine braking when going downhill. Do not coast.
- Do not drink and drive!
- Comply with state and local laws governing highway safety and movement of farm machinery on public roads.
- Use approved accessory lighting flags and necessary warning devices to protect operators of other vehicles on the highway during daylight and nighttime transport. Various safety lights and devices are available from your dealer.
- The use of flashing amber lights is acceptable in most localities. However, some localities prohibit their use. Local laws should be checked for all highway lighting and marking requirements.
- When driving the tractor and equipment on the road or highway under 40 kph (20 mph) at night or during the day, use flashing amber warning lights and a slow moving vehicle (SMV) identification emblem.
- Plan your route to avoid heavy traffic.
- Be a safe and courteous driver. Always yield to oncoming traffic in all situations, including narrow bridges, intersections, etc.
- Be observant of bridge loading ratings. Do not cross bridges rated lower than the gross weight as which you are operating.

- Watch for obstructions overhead and to the side while transporting.
- Always operate equipment in a position to provide maximum visibility at all times. Make allowances for increased length and weight of the equipment when making turns, stopping the unit, etc.
- Pick the levellest possible route when transporting across fields. Avoid the edges of ditches or gullies and steep hillsides.
- Be extra careful when working on inclines.
- Maneuver the tractor or towing vehicle at safe speeds.
- Avoid overhead wires or other obstacles. Contact with overhead lines could cause serious injury or death.
- Avoid loose fill, rocks and holes; they can be dangerous for equipment operation or movement.
- Allow for unit length when making turns.
- Operate the towing vehicle from the operator's seat only.
- Never stand alongside of unit with engine running or attempt to start engine and/or operate machine while standing alongside of unit.
- Never leave running equipment attachments unattended.
- As a precaution, always recheck the hardware on equipment following every 100 hours of operation. Correct all problems. Follow the maintenance safety procedures.

Operation

Before attaching the rotary tiller to the tractor, check the unit to ensure there is oil in the top and side gearbox and the right rotor bearing. See Maintenance section for lubricant specifications.

Before beginning operation, check oil and grease points.

Note: Gearboxes are shipped with high performance gear grease, add indicated lubricants.

Oil Level:

Center Gearbox: Level indicated on dipstick (SAE 90)
Side Gear drive Fill to oil drain plug on lower front of cover (SAE 140)
Right Rotor Bearing: Grease if cap has grease nipple. Otherwise fill to side drain plug. (SAE 90 OR SAE 140)

Grease: PTO shaft Cross & Bearings



Attaching to the tractor

1. With the Rotary Tiller on a level surface, back the Cat. 1 or 2 tractor so the tractor lift arms are even with the unit's lower hitch pins. Lower or raise the tractor hitch arms until the 7/8" bushing in the arm is inside the clevis of lower hitch points. **Be sure nothing is between the tractor and the tiller before backing up.**
2. Insert the lower hitch pin through the lower hitch blocks and the tractor arm. The YCT series tillers have adjustable lower hitch blocks that can be slide to facilitate usage on larger tractors.
3. Secure the lift arm in place by using a 7/16" lynch pin or other fastener.
4. Repeat with the other arm.
5. Connect the driveline to the tractor's PTO output shaft. Secure it in place.
6. Connect the tractor top link to the upper hitch point of the rotary tiller.
7. Start the tractor and slowly raise the tiller. Check for drawbar interference. Be sure that the PTO driveline does not bottom out when lifting the machine to its maximum height. If it does appear that it could bottom out, it is necessary to shorten the PTO driveline. (See Shortening a PTO Driveline section). Ensure that in the working position there is an overlap of a minimum of 1/3 the length of each profile.

Shortening a PTO Driveline

1. With the implement attached to the tractor's three point hitch, and the PTO driveline not installed, separate the PTO driveline. Attach the implement end to the implement and the other end to the tractor PTO input shaft.
2. Raise the implement by using the tractor's hydraulic 3-point hitch to its maximum lift height.
3. Hold the half shafts next to each other and mark them so each end is approximately 1/2" from hitting the end of the telescopic profiles.

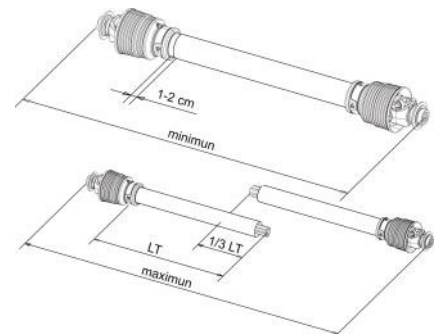

- Shorten the inner and out guard tubes equally.
- Shorten the inner and outer profiles by the same length as the guard tubes. Using a rattail file, round off all sharp edges and burrs. Grease the telescopic profile generously before reassembling.



Do not shorten too much, the proper overlap is a minimum of 1/3 the length of each profile.

Caution: Slip Clutches may become hot. Do Not Touch. Keep the slip clutch area clear of an material that may catch fire.

Slip clutches have adjustable torque settings. The torque setting varies with the different compression of each spring. All the springs should have an equal amount of compression.

IMPORTANT: Do not over-tighten the compression nuts as this may impair performance or cause premature wearing of the slip clutch.

Slip Clutch adjustments

Slip Clutch must be adjusted before first use or after a storage period.

- Using a marker, scribe a line across the exposed edges of the clutch plate and friction discs.
- Back off compression nuts to free friction discs by turning each nut *exactly* 2 revolutions.
- Start the tractor and run the driveline at a low idle to slip the friction discs. This will remove the dirt, corrosion and surface floss from the clutch plate faces.
- Disengage PTO, shut down tractor and wait for all components to come to a complete stop.
- Inspect the clutch and ensure that the scribed markings on the disc and plates have changed position. If any two marks are still aligned, this is an indication that these discs have not slipped. It may be necessary to completely disassemble the clutch to free them up.
- After ensuring all discs are free, tighten the compression nuts, uniformly, *exactly* 2 revolutions to reset the clutch original pressure, where the springs are 1 1/4" compressed length..

Working Depth Adjustment

The working depth is controlled by raising or lowering the side skids. If the skids are raised, the working depth increases. By lowering the skids, the tilling depth with decrease.

Tailgate adjustment

Position the tailgate to its desired opening by fitting the bolts into the appropriate holes of the adjustment flange located on the top of the main frame. To adjust the degree of tension, tighten or loosen up on the 24mm nut on the top of the spring support rod.



Multi-Speed Gearbox

On certain models, the tiller will come standard with a multi-speed gearbox to allow rotor speed changes. This is very useful on uneven ground so the tractor speed can maintain a constant ground speed and change the rotor speed in order to adapt to different soil conditions. In order to change the rotor speed:



- Ensure the gearbox is not too hot to work safely without burning ones hands.
- Tilt the tiller forward to prevent excessive oil from coming out of the back cover.
- Unscrew the bolt holding the rear cover of the gearbox.
- Adjust the gears inside the gearbox in order to obtain the desired speed.
- Replace cover and tighten bolts.
- IMPORTANT: Make sure the spacers located behind the gears do not fall into the gearbox! If this happens damage to the gearbox or gears can occur.**



BXV				CXT			
INPUT	Left Gear	Right Gear	Rotor Speed	INPUT	Left Gear	Right Gear	Rotor Speed
540	22	16	140	540	23	17	143
540	20	18	174	540	21	19	175
540	18	20	213	540	19	21	214
540	16	22	266	540	17	23	262

Gear Adjustment

Start up

After making the necessary adjustments, lower the rotary tiller until the blades are a couple of inches from the ground. Engage the PTO and slowly lower the tiller to begin working.

Removal and Storage

After finishing, remove the rotary tiller from the tractor.

1. Put the PTO driveline in a safe location so it will not become damaged.
2. Clean and dry the equipment.
3. Replace any damaged or worn parts.
4. Check all bolts and nuts for tightness.
5. Lubricate and protect the machine from the elements.



FOLLOWING OPERATION

- Following operation, or when unhitching, stop the tractor or towing vehicle, set the brakes, disengage the PTO and all power drives, shut off the engine and **remove the ignition keys**.
- Store the unit in an area away from human activity.
- Do not park equipment where it will be exposed to livestock for long periods of time. Damage and livestock injury could result.
- Do not permit children to play on or around the stored unit.
- Make sure all parked machines are on a hard, level surface and engage all safety devices.
- Wheel chocks may be needed to prevent unit from rolling.



PERFORMING MAINTENANCE

- Good maintenance is your responsibility. Poor maintenance is an invitation to trouble.
- Make sure there is plenty of ventilation. Never operate the engine of the towing vehicle in a closed building. The exhaust fumes may cause asphyxiation.
- Be certain all moving parts on attachments have come to a complete stop before attempting to perform maintenance.
- Always use the proper tools or equipment for the job at hand.
- Use extreme caution when making adjustments.
- Never replace hex bolts with less than grade five bolts unless otherwise specified.
- After servicing, be sure all tools, parts and service equipment are removed.
- Where replacement parts are necessary for periodic maintenance and servicing, genuine factory replace-

ment parts must be used to restore your equipment to original specifications. The manufacturer will not claim responsibility for use of unapproved parts and/or accessories and other damages as a result of their use.

- If equipment has been altered in any way from original design, the manufacturer does not accept any liability for injury or warranty.

MAINTENANCE

8 hours	Check oil in Rotor (<i>90wt</i>) Grease PTO shaft cross & bearings (<i>GP grease</i>) Check Hardware for tightness
16 hours	Check oil level in center gearbox (<i>90wt</i>) Check oil level in side gearbox (<i>140wt</i>) Check oil level in rotor. (<i>90wt</i>) Check Hardware for tightness
200 hours	Replace oil in center gearbox (<i>90wt</i>) Replace oil in side gearbox (<i>140wt</i>) Check Hardware for tightness

Replacing Blades

In order for the tiller to perform optimally, make sure the tiller blades are in good working condition and their bolts and nuts tight. Always replace the blades with the bolt head against the blade and the washer and nut on the flange side to help prevent the blades from loosening.

When several blades are to be replaced, replace them one blade at a time in order maintain the scroll pattern on the rotor.

Note: To determine Left or Right Blades, hold the blade by the bolt hole end and the cutting edge facing downward. If the blade curves to the left it is a left hand blade, curving to the right indicates a right hand blade.

Tar River Implement

RXT-080 - RXT-088 - RXT-096 (Version 1-2)

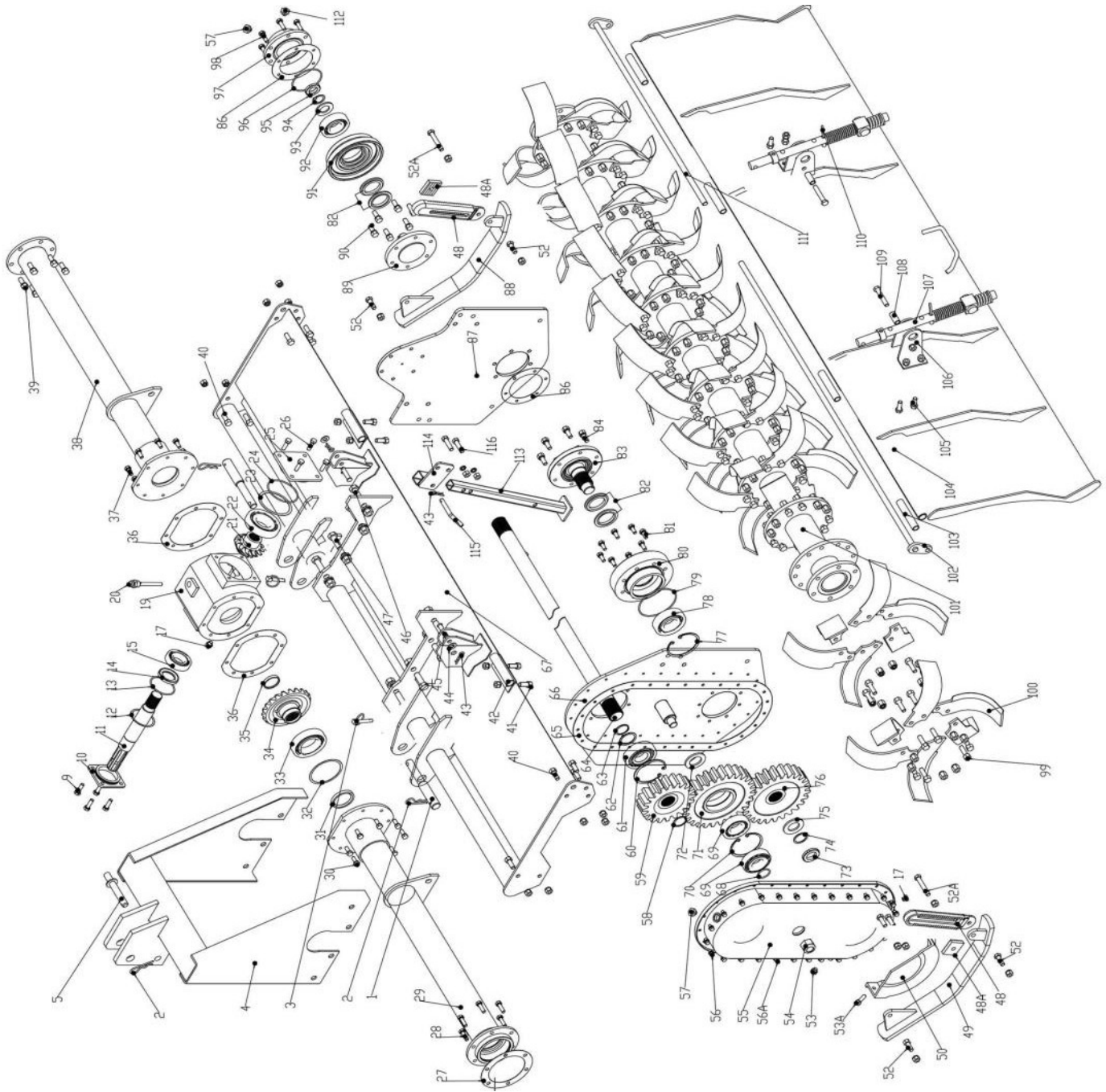

Tai River Implement

RXT-080 - RXT-088 - RXT-096 (Version 1-2)

POS.	Part #	Description	Qty
1	SB100755	Lower Hitch Pin - Cat. 1 & 2	2
2	RC4	R-Clip- M4	4
3	SB100756	Lynch pin	2
4	RXA0100	A-Frame	1
5	YT1066010204	Top Hitch Pin Cat. 1	1
9	BM101520	Bolt- M10 x 1.5 x 20	4
9A	RX0304-1	Shield- Gearbox	1
9B	BM0812516	Bolt- M8 x 1.25 x 16	3
9C	RX0304-2	Shield Support - Gearbox	1
10	RX0310	Cap - Front Gearbox	1
11	RX0309	Input Shaft	1
12	OR75x3.55	O-Ring- M75 x 3.55	1
13	RX0311	Shim-Input Cap- M80 x 70 x 0.4	2
14	OS406508	Oil Seal- M40 x 65 x 8	1
15	B6208	Bearing- 6208	1
16	RX0016	Shim- Input Bearing- M50 x 40 x 2	1
17	OP12125	Oil Plug- M12 X 1.25	2
18	SRE-40	Snap Ring- Pinion Gear - Front	1
19	RX0305	Housing Gearbox	1
20	RX02003000	Gearbox Oil Dipstick	1
21	RX0308	Pinion Gear	1
22	B30310	Bearing- 30310	1
23	RX0306	Gearbox Back Gasket	2
24	OR35x5.5	O-Ring- M35 x 5.5	1
25	RX0307	Gearbox Cap	1
26	BM101525	Bolt- M10 x 1.5 x 25	1
27	RX0315	Gasket - Drive shaft	1
28	BM101525	Bolt- M10 x 1.5 x 25	6
29	RX0301-80	Drive Shaft Tube Housing- RXT-080	1
29	RX0301-88	Drive Shaft Tube Housing- RXT-088	1
29	RX0301-96	Drive Shaft Tube Housing- RXT-096	1
30	BM101525	Bolt- M10 x 1.5 x 25	8
31	OS557209	Oil Seal- M55 x 72 x 9	1
32	RX0303	Gasket- Drive shaft tube housing	3
33	B6212	Bearing- 6212	1
34	RX0304	Ring Gear	1
35	RX0904	Cap- M52	1
36	RX0314	Gasket - Center Gearbox Left Side	2
37	BM1012530	Bolt- M10 x 1.25 x 25	8
38	RX0905-80	Gearbox Support Tube- RXT-080	1
38	RX0905-88	Gearbox Support Tube- RXT-088	1
38	RX0905-96	Gearbox Support Tube- RXT-096	1
39	BM1217525	Bolt- M12 x 1.75 x 25	8
40	BM1217535	Bolt- M12 x 1.75 x 35	12
41	BM1217525	Bolt- M12 x 1.75 x 25	4
42	RX0206	Hanger - Tailgate	2

Belco
2019-12-30 12:55:27

OR95X3.55

RXT-080 1

RXT-088 1

RXT-096 1

Tar River Implement

RXT-080 - RXT-088 - RXT-096 (Version 1-2)

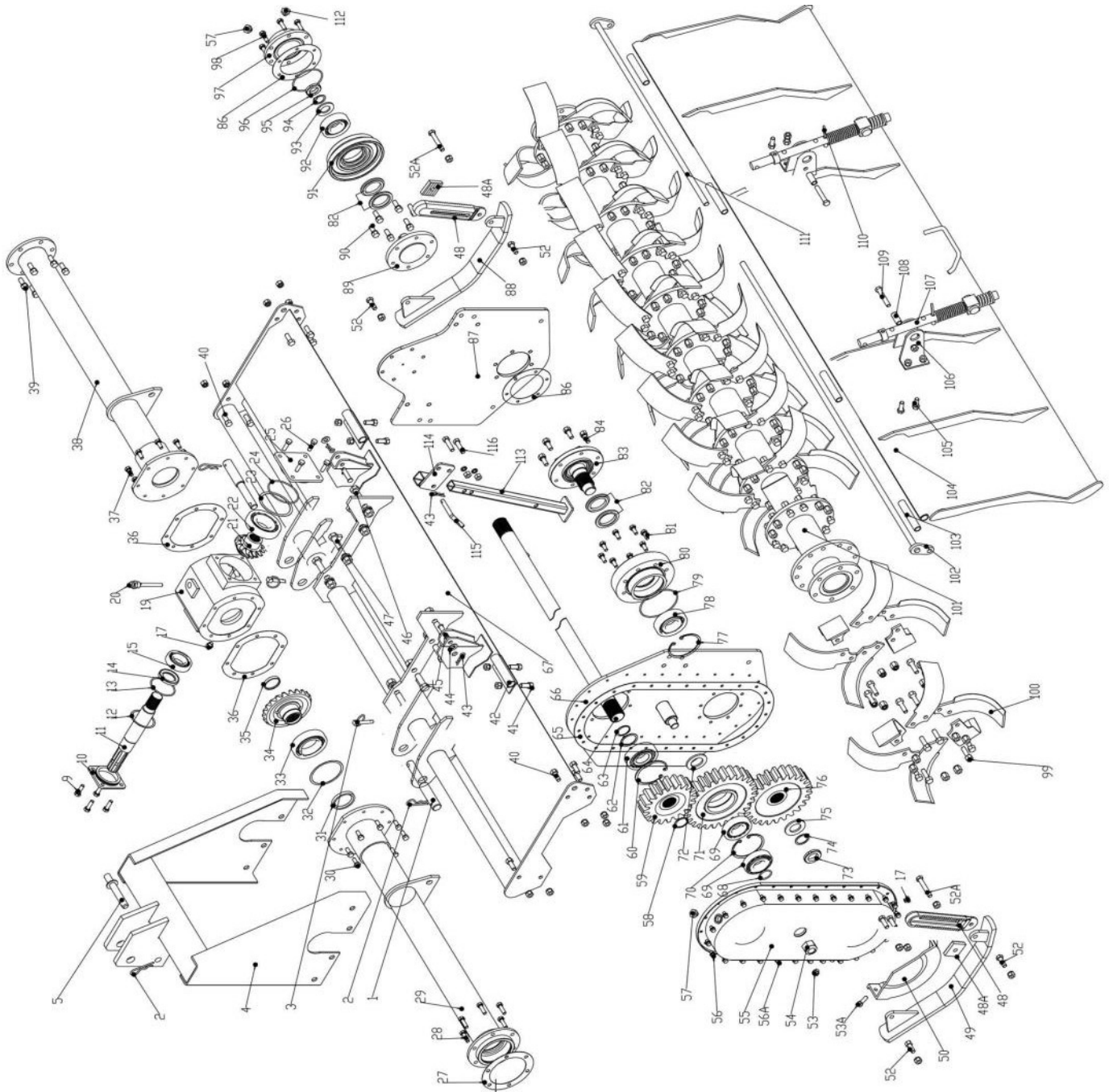

Tar River Implement

RXT-080 - RXT-088 - RXT-096 (Version 1-2)

POS.	Part #	Description	Qty
43	RC3	R-Clip- Tailgate Adjustment	2
45	RX0205	Pin- Tailgate Adjustment	2
46	BM162050	Bolt- M16 x 2.0 x 50	2
47	BM162040	Bolt- M16 x 2.0 x 40	6
48	RX0600	Skid Support (Version 1)	2
48	BV0801	Skid Adjustment Bracket (Version 2)	2
48A	BV0802	Skid Adjustment Stop (Version 2)	2
49	RX0601	Skid Weldment - Left (Version 1)	1
	RXG0601	Skid Weldment—Left (Version 2)	1
50	RX0502	Skid shield	1
51	RX0505	Skid Bracket	1
52	BM1217535	Bolt- M12 x 1.75 x 35	10
52A	BM1212560	Bolt- M12 x 1.25 x 60	2
53	OP1212500	Oil Plug- M12	1
53A	BM1217520	Bolt- M12 x 1.75 x 20	1
54	LN2415	Lock Nut- M24 x 1.5 (Fine Thread)	1
55	RX0503	Side Drive Cover	1
56	BM812525	Bolt- M8 x 1.25 x 25	23
56A	BM812516	Bolt- M8 x 1.25 x 16	4
57	DP1615B	Breather cap- Side housing	1
58	SRE-45	Snap Ring- External- M45	1
59	RX0506	Top Gear	1
60	SRI-100	Snap Ring - Top Gear Bearing	1
61	BNUP309E	Bearing- BNUP309E	1
62	RX0301	Gasket - Drive side- Top Gear	1
63	SRE-45	Snap Ring- External- M45	1
64	RX0302-80	Drive Shaft- RXT-080	1
64	RX0302-88	Drive Shaft- RXT-088	
64	RX0302-96	Drive Shaft- RXT-096	
65	RX0500	Gasket- Side Gear Case	1
66	RX0501	Side Panel- Left (Version 1)	1
	RXG0501	Side Panel- Left (Version 2)	1
67	RX0201-80	Frame Weldment - RXT-080	1
67	RX0201-88	Frame Weldment - RXT-088	
67	RX0201-96	Frame Weldment - RXT-096	
68	OR35x5.5	O-Ring- M35 x 5.5	1
69	B30307	Bearing- 30307	2
70	SRI-90	Snap Ring- Internal- M90	1
71	RX0507	Idler Gear	1
72	RX0509	Spacer	1
73	T810-1998	Nut- M36 x 1.5	2
74	SRE-35	Snap Ring- External- M35	2

Tar River Implement

RXT-080 - RXT-088 - RXT-096 (Version 1-2)

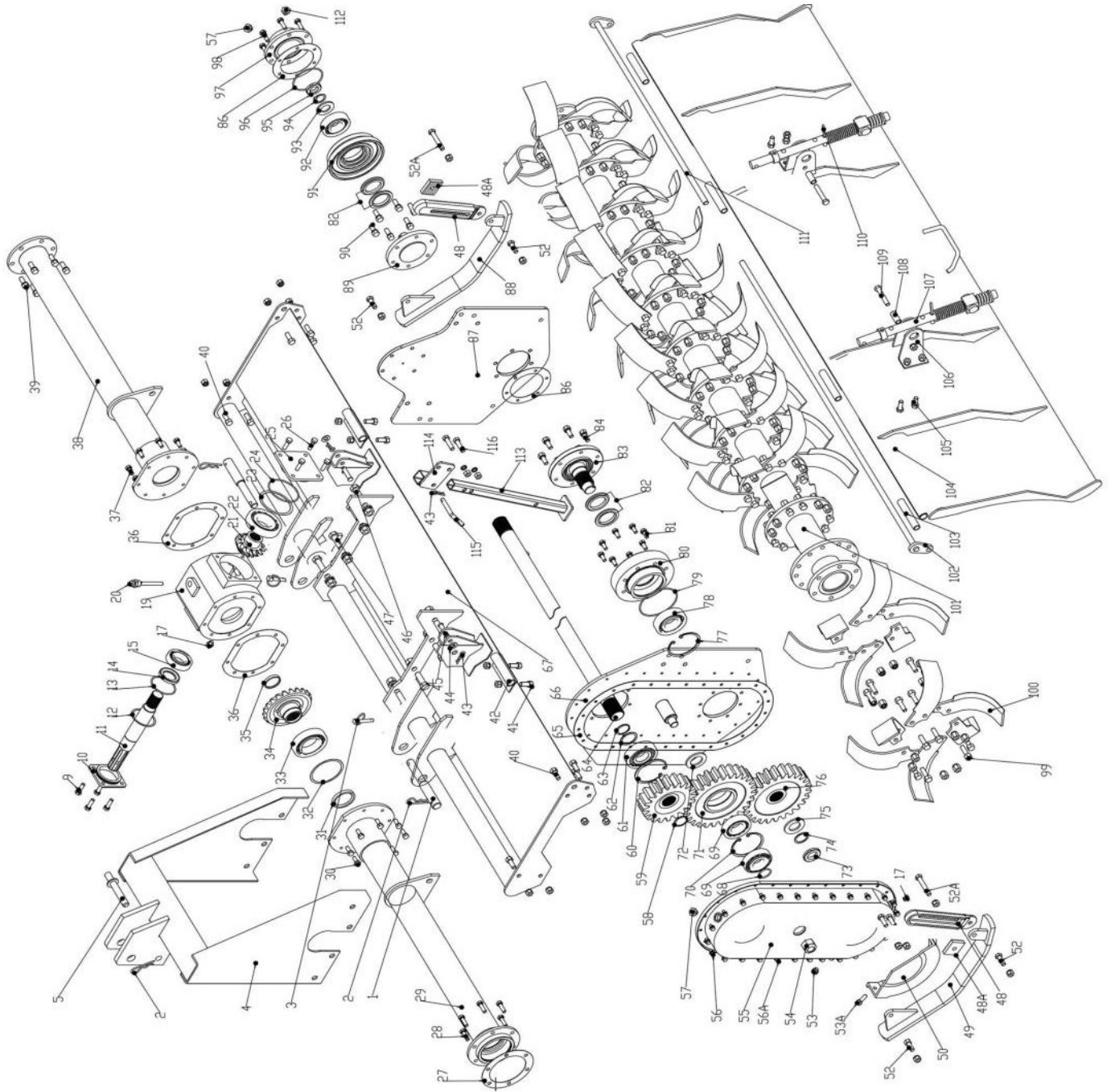

Tar River Implement

RXT-080 - RXT-088 - RXT-096 (Version 1-2)

POS.	Part #	Description	Qty
75	FW36	Flat Washer- M36	1
76	RX0508	Bottom Gear	1
77	SRI-100	Snap Ring- Internal- M100	1
78	B6309	Bearing- 6309	1
79	OR122x3.55	O-Ring- M122 x 3.55	1
80	RX0402	Bearing Support - Left Side	1
81	BM101525	Bolt- M10 x 1.5 x 25	8
82	OS53576085	Oil Seal- M53.5 x 76 x 8.5	2
83	RX0401	Rotor Support shaft - Left side	1
84	BM1217530	Bolt- M12 x 1.75 x 30	6
85	RX0204	Protector- Right Side	1
86	RX0406	Gasket- Rotor	2
87	RX0201	Side Panel- Right (Version 1)	1
	RXGU0201	Side Panel- Right (Version 2)	
88	RX0602	Skid Weldment- Right (Version 1)	1
	RXG0602	Skid Weldment- Right (Version 2)	
89	RX0403	Rotor Support Shaft - Right side	1
90	BM101530	Bolt- M10 x 1.5 x 30	6
91	RX0404	Bearing Support	1
92	B6308	Bearing- 6308	1
93	FW30	Flat Washer- M30	1
94	SRE-30	Snap Ring- External- M30	1
95	SNM3015	Spanner Nut- M30 x 1.5	1
96	OR92.5x3.55	O-Ring- 92.5 x 3.55	1
97	RX0405	End Cap- Rotor Right side	1
98	BM101535	Bolt- M10 x 1.5 x 35	6
99	BM141540	Bolt- M14 x 1.5 x 40	-
	NM1415	Nut- M14 x 1.5	-
100	RX0407L	Blade- Left (Version 1)	30-33-36
100	RX0407R	Blade- Right (Version 1)	30-33-36
100	RXU0407L	Blade- Left (Version 2)	28-30-33
100	RXU0407R	Blade- Right (Version 2)	28-30-33
101	RX0401-80	Rotor- RXT-080 (Version 1)	1
101	RX0401-88	Rotor- RXT-088 (Version 1)	1
101	RX0401-96	Rotor- RXT-096 (Version 1)	1
101	RXU0401-80	Rotor- RXT-080 (Version 2)	1
101	RX0U401-88	Rotor- RXT-088 (Version 2)	1
101	RX04U01-96	Rotor- RXT-096 (Version 2)	1
102	RX0701L-80	Rod- Tailgate- RXT-080 Left	1
102	RX0701L-88	Rod- Tailgate- RXT-088 Left	1
102	RX0701L-96	Rod- Tailgate- RXT-096 Left	1
103	RX0708	Rod Tube- Nylon	1

Tar River Implement

RXT-080 - RXT-088 - RXT-096 (Version 1-2)

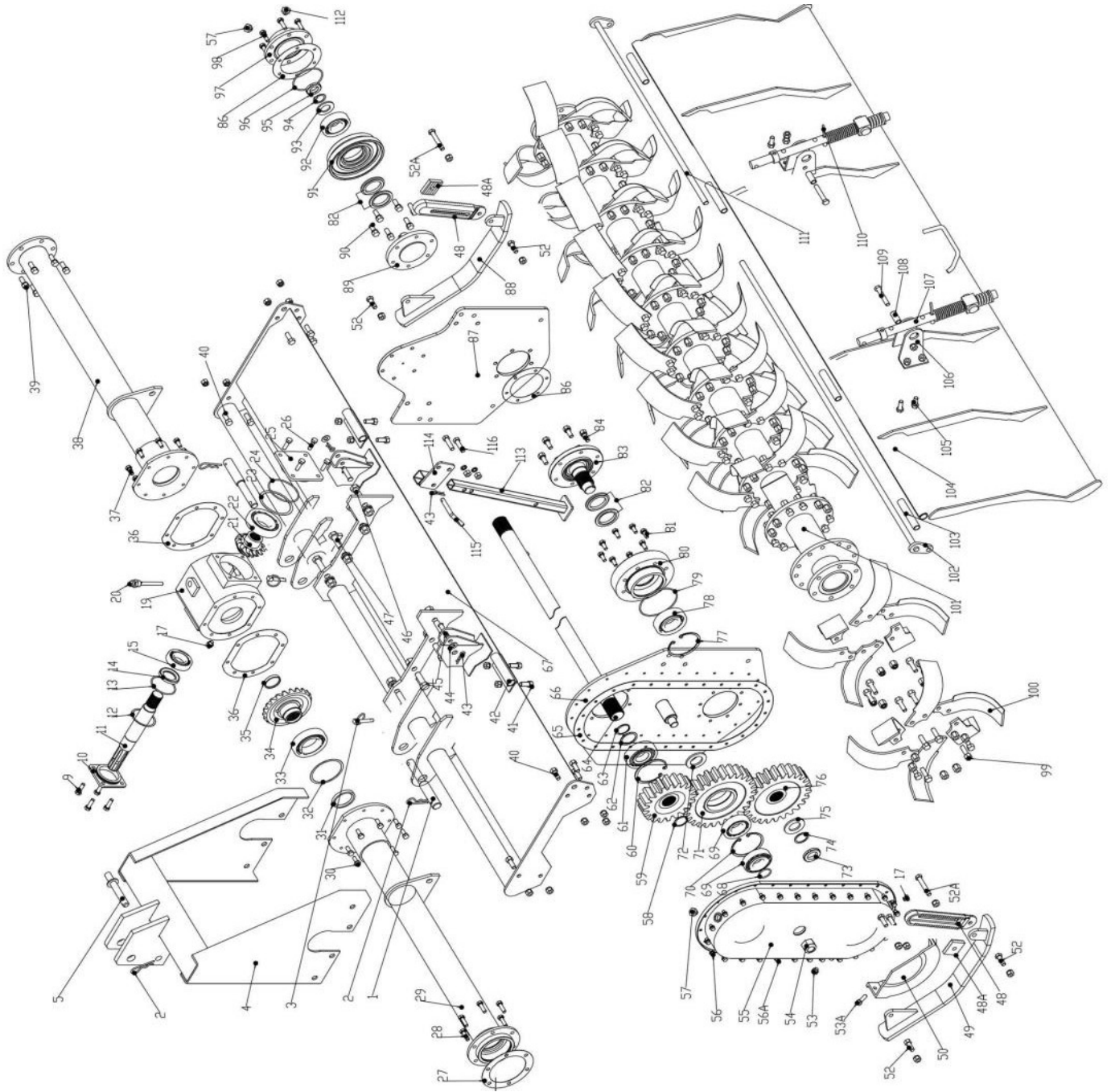

Tar River Implement

RXT-080 - RXT-088 - RXT-096 (Version 1-2)

POS.	Part #	Description	Qty
104	RX0702-80	Tailgate RXT-080	1
104	RX0702-88	Tailgate RXT-088	1
104	RX0702-96	Tailgate RXT-096	1
105	BM1217525	Bolt- M12 x 1.75 x 25	4
106	RX0702	Bracket- Tailgate Spring	2
107	RX0703	Rod- Tailgate Spring	2
108	RX0701	Bushing- Tailgate	2
109	BM1217570	Bolt- M12 x 1.75 x 70	2
110	RX0707	Spring- Tailgate	4
111	RX0701R-80	Rod- Tailgate RXT-080 Right	1
111	RX0701R-88	Rod- Tailgate RXT-088 Right	1
111	RX0701R-96	Rod- Tailgate RXT-096 Right	1
113	RX0801	Stand	1
114	RX0802	Bracket- Stand	1
115	YT10660501	Pin	1
116	BM1217530	Bolt- M12 x 1.75 x 30	2
	RXTGBC001	Gearbox Complete (Version 1-2)	
	147125	Complete PTO - Series 60 - 200mm Slip Clutch	
	180-510-60	Friction Disc - 6 1/3"OD	

Tar River Implement

RXT-080 - RXT-088 - RXT-096 (Version 3)

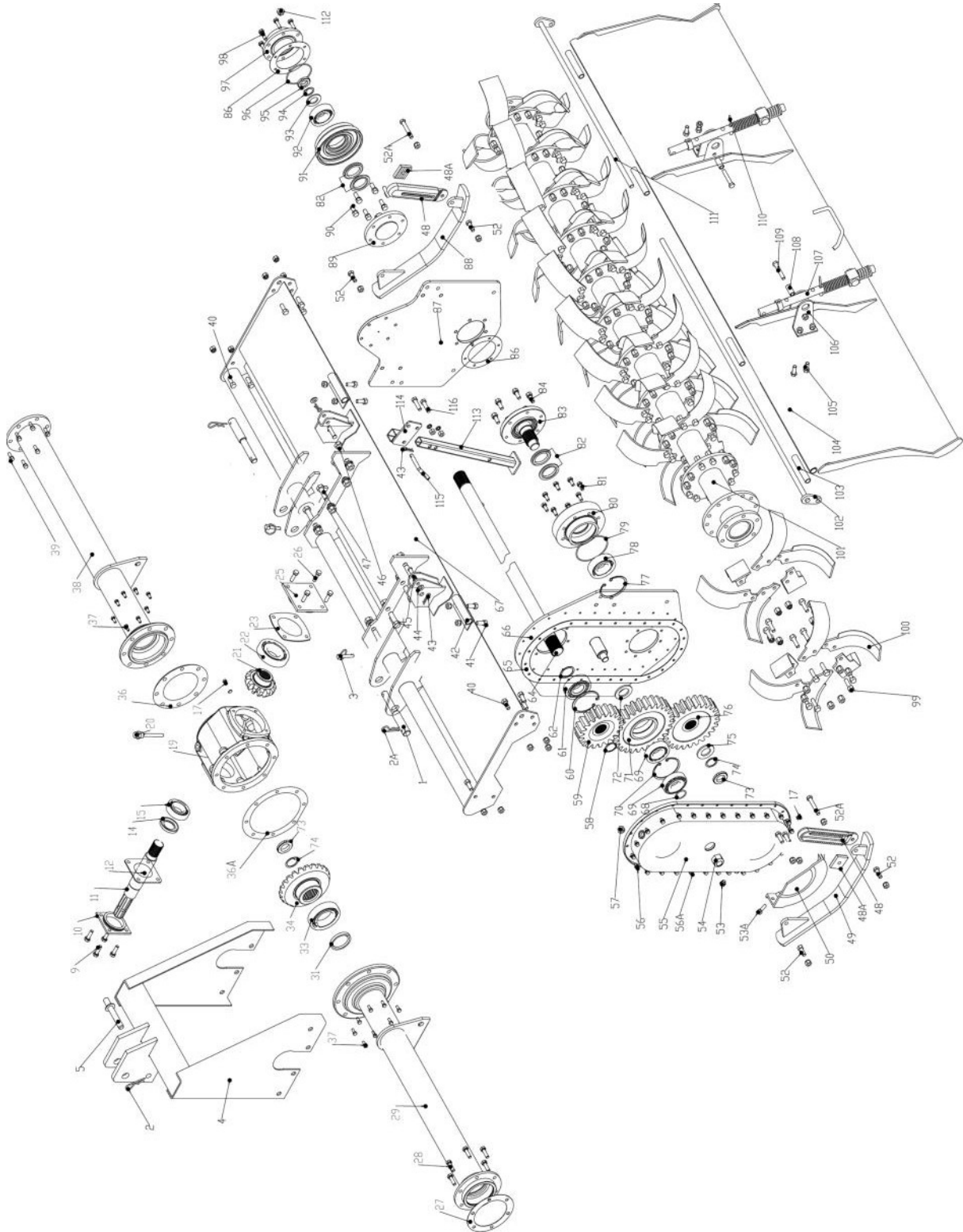

Tar River Implement

RXT-080 - RXT-088 - RXT-096 (Version 3)

POS.	Part #	Description	Qty
1	SB100755	Lower Hitch Pin- Cat. 1 & 2	2
2	RC4	R-Clip- M4	4
3	LYNPN10	Lynch pin- M10	2
4	RXA0100	A Frame	1
5	YT1066010204	Top Hitch Pin Cat. 1	1
9	BM101520	Bolt- M10 x 1.5 x 20	4
9A	RX0304-1	Shield- Gearbox	1
9B	BM0812516	Bolt- M8 x 1.25 x 16	3
9C	RX0304-2	Shield Support - Gearbox	1
10	RX0A310	Cap- Front Gearbox	1
11	RXA0309	Input Shaft	1
12	RX0906	Gasket- Input Shaft	1
14	OS406508	Oil Seal- M40 x 65 x 8	1
15	B30208	Bearing- 30208	1
17	OP12125	Oil Plug- M12 x 1.25	2
19	RXA0305	Housing - Gearbox	1
20	RX02003000	Gearbox Oil Plug	1
21	RXA0308	Pinion Gear	1
22	B30212	Bearing- 30212	1
23	RXA0306	Gearbox Back Gasket	2
25	RXA0307	Gearbox Cap	1
26	BM101530	Bolt- M10 x 1.5 x 30	4
27	RX0315	Gasket - Drive shaft	1
28	BM101525	Bolt- M10 x 1.5 x 25	6
29	RX0301-80	Drive Shaft Tube Housing- RXT-080	1
29	RX0301-88	Drive Shaft Tube Housing- RXT-088	1
29	RX0301-96	Drive Shaft Tube Housing- RXT-096	1
30	BM101525	Bolt- M10 x 1.5 x 25	8
31	OS458012	Oil Seal- M45 x 80 x 12	1
33	B6217	Bearing- 6217	1
34	RXA0304	Ring Gear	1
36	RX0907	Gasket - Center Gearbox Right Side	1
36A	RXA0314	Gasket - Center Gearbox Left Side	1
37	BM1012530	Bolt- M10 x 1.25 x 25	8
38	RX0905-80	Gearbox Support Tube- RXT-080	1
38	RX0905-88	Gearbox Support Tube- RXT-088	1
38	RX0905-96	Gearbox Support Tube- RXT-096	1
39	BM1217525	Bolt- M12 x 1.75 x 25	8
40	BM1217535	Bolt- M12 x 1.75 x 35	12

Tar River Implement

RXT-080 - RXT-088 - RXT-096 (Version 3)

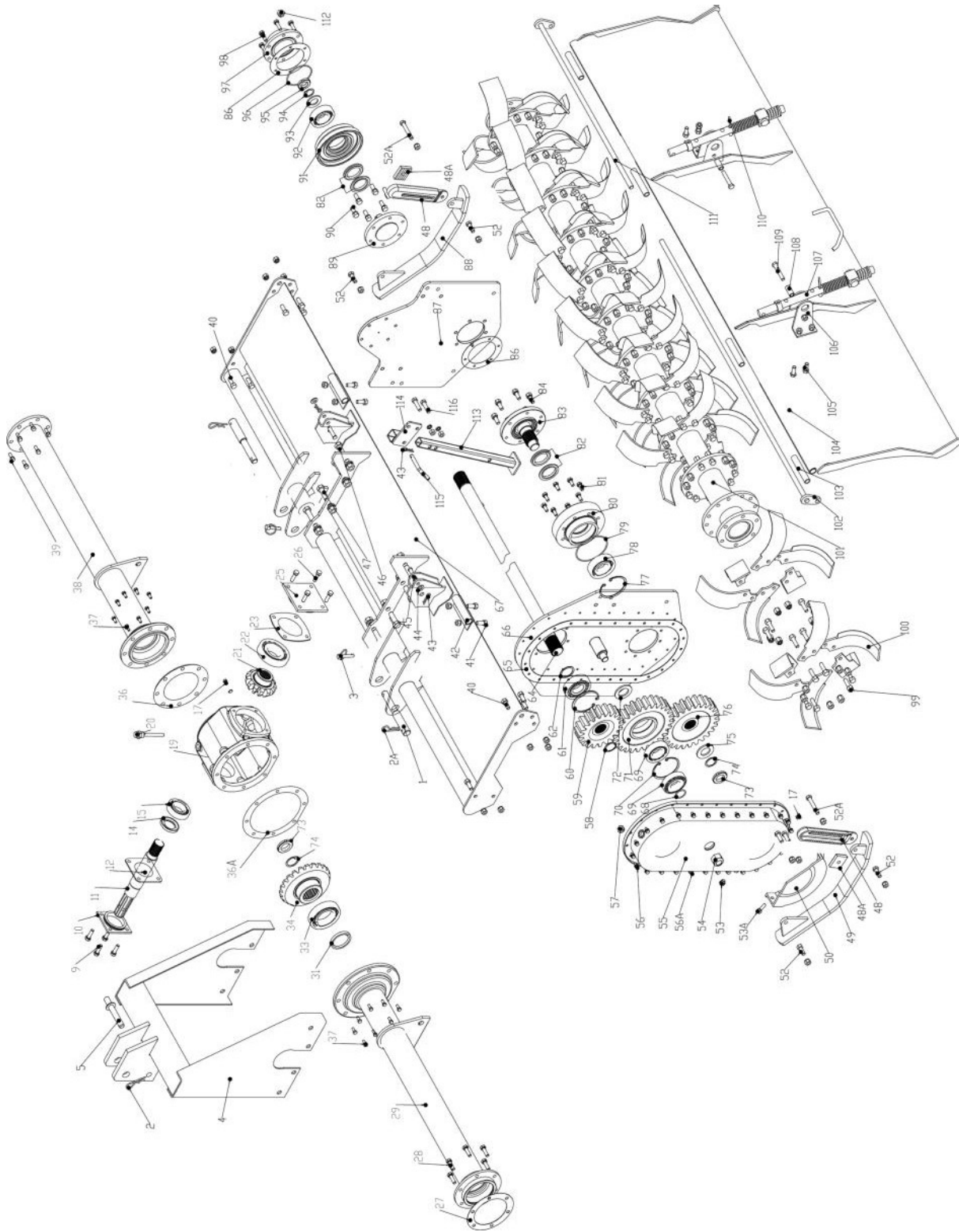

Tar River Implement

RXT-080 - RXT-088 - RXT-096 (Version 3)

POS.	Part #	Description	Qty
41	BM1217525	Bolt- M12 x 1.75 x 25	4
42	RX0206	Hanger- Tailgate	2
43	RC3	R-Clip- Tailgate Adjustment	2
45	RX0205	Pin- Tailgate Adjustment	2
46	BM162050	Bolt- M16 x 2.0 x 50	2
47	BM162040	Bolt- M16 x 2.0 x 40	6
48	RX0600	Skid Support	2
48	BV0801	Skid Adjustment Bracket	2
48A	BV0802	Skid Adjustment Stop	2
49	RXG0601	Skid Weldment- Left	1
50	RX0502	Skid Shield	1
51	RX0505	Skid Bracket	1
52	BM1217535	Bolt- M12 x 1.75 x 35	10
52A	BM1212560	Bolt- M12 x 1.25 x 60	2
53	OP12125	Oil Plug- M12 x 1.25	1
53A	BM1217520	Bolt- M12 x 1.75 x 20	1
54	LN2415	Self-locking Nut- M24 x 1.5	1
55	RX0503	Side Drive Cover	1
56	BM0812525	Bolt- M8 x 1.25 x 25	23
56A	BM0812516	Bolt- M8 x 1.25 x 16	4
57	OP1415V	Oil Plug Vented- M14 x 1.5	1
58	T810-1998	Spanner Nut- M36 x1.5	1
59	RX0506	Top Gear	1
60	SRI-100	Snap Ring- Internal- Top Gear Bearing	1
61	BNUP309E	Bearing- BNUP309E	1
62	RX0301	Gasket - Drive side- Top Gear	1
63	SRE-45	Snap Ring- External- M45	1
64	RXU0302-80	Drive Shaft- RXT-080	1
64	RXU0302-88	Drive Shaft- RXT-088	
64	RXU0302-96	Drive Shaft- RXT-096	
65	RX0500	Gasket- Side Gear Case	1
66	RXG0501	Side Panel-Left	1
67	RX0201-80	Frame Weldment- RXT-080	1
67	RX0201-88	Frame Weldment- RXT-088	
67	RX0201-96	Frame Weldment- RXT-096	
68	OR35x5.5	O-Ring- M35 x 5.5	1
69	B30307	Bearing- 30307	2
70	SRI-90	Snap Ring- Internal- M90	1

Tar River Implement

RXT-080 - RXT-088 - RXT-096 (Version 3)

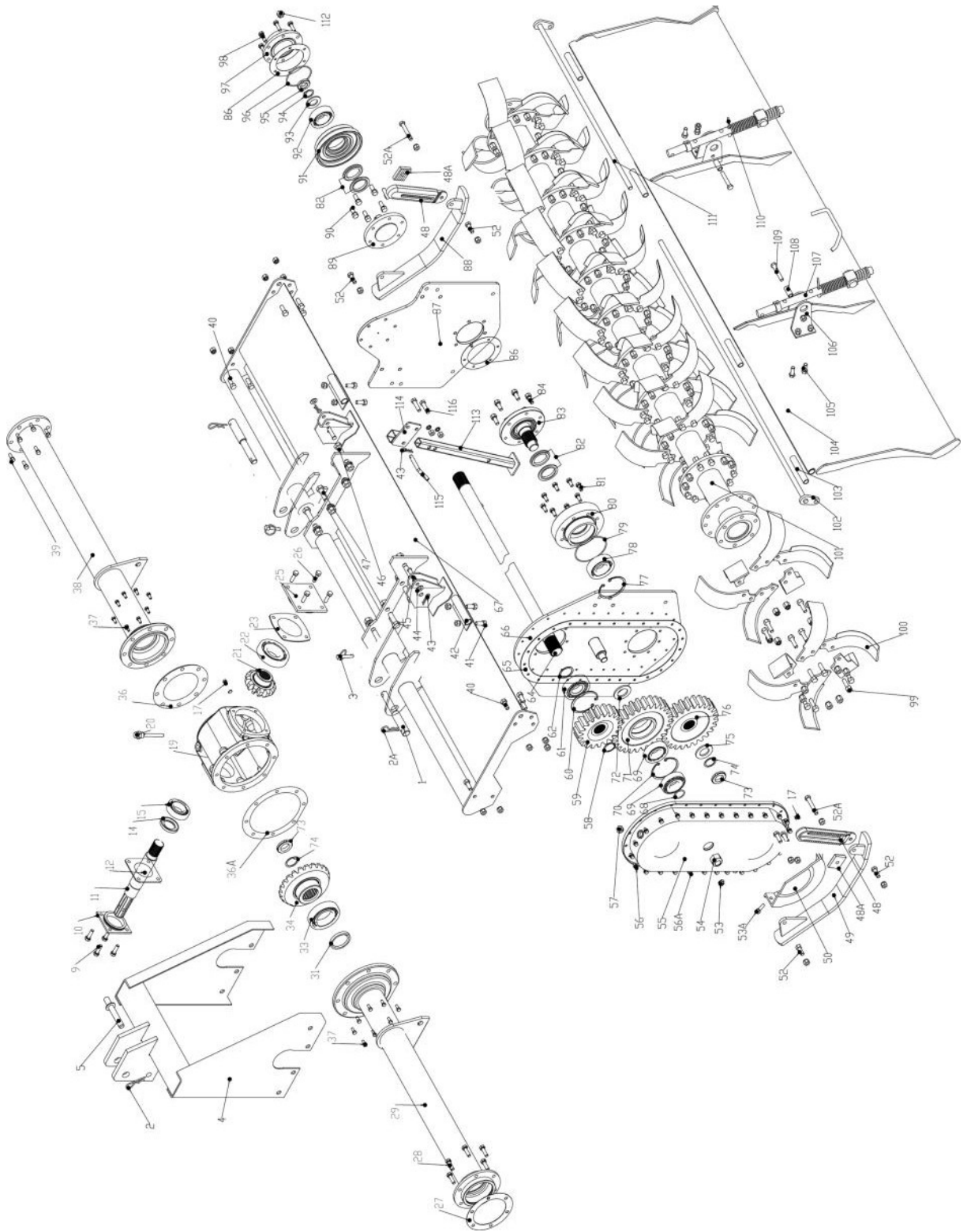

Tar River Implement

RXT-080 - RXT-088 - RXT-096 (Version 3)

POS.	Part #	Description	Qty
71	RX0507	Idler Gear	1
72	RX0509	Spacer	1
73	T810-1998	Nut- M36 x 1.5	2
74	SRE-35	Snap Ring- External- M36	2
75	FW36	Flat Washer- M36	1
76	RX0508	Bottom Gear	1
77	SRI-100	Snap Ring- Internal- M100	1
78	B6309	Bearing- 6309	1
79	OR122x3.55	O-Ring- M122 x 3.55	1
80	RX0402	Bearing Support- Left Side	1
81	BM101525	Bolt- M10 x 1.5 x 25	8
82	OS53576085	Oil Seal- M53.5 x 76 x 8.5	2
83	RX0401	Rotor Support shaft- Left side	1
84	BM1217530	Bolt- M12 x 1.75 x 30	6
85	RX0204	Protector- Right Side	1
86	RX0406	Gasket- Rotor	2
87	RXGU0201	Side Panel- Right	
88	RXG0602	Skid Weldment- Right	
89	RX0403	Rotor Support shaft- Right side	1
90	BM101530	Bolt- M10 x 1.5 x 30	6
91	RX0404	Bearing Support	1
92	B6308	Bearing- 6308	1
93	FW30	Flat Washer- M30	1
94	SRE-30	Snap Ring- External- M30	1
95	SNM30150	Spanner Nut- M30 x 1.5	1
96	OR92.5x3.55	O Ring- M92.5 x 3.55	1
97	RX0405	End Cap- Rotor Right side	1
98	BM101535	Bolt- M10 x 1.5 x 35	6
99	BM141540	Bolt- M14 x 1.5 x 40	-
	NM1415	Nut- M14 x 1.5	-
100	RXU0407L	Blade - Left	28-30-33
100	RXU0407R	Blade - Right	28-30-33
101	RXU0401-80	Rotor- RXT-080	1
101	RX0U401-88	Rotor- RXT-088	1
101	RX04U01-96	Rotor- RXT-096	1

Tar River Implement

RXT-080 - RXT-088 - RXT-096 (Version 3)

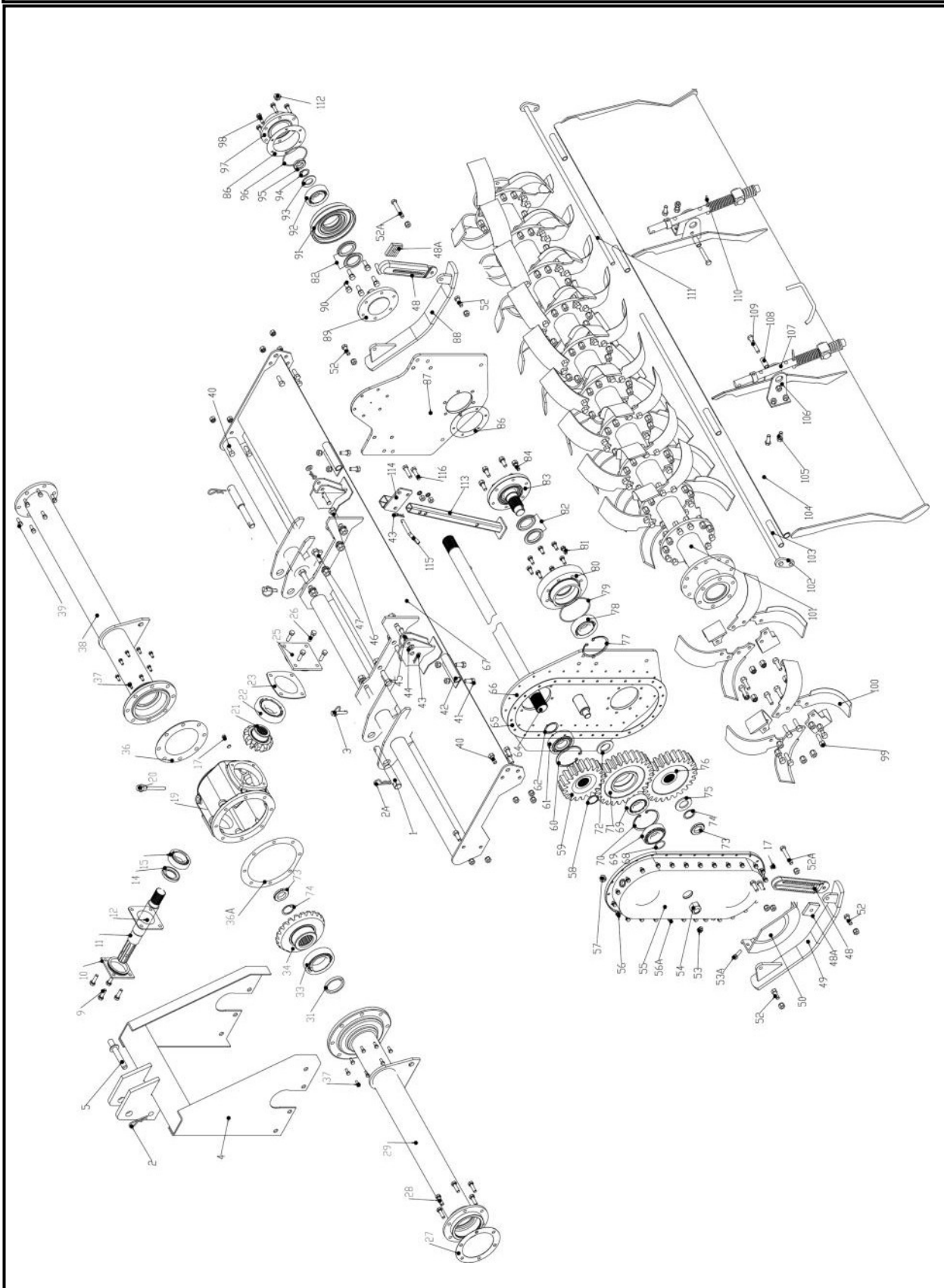

Tar River Implement

RXT-080 - RXT-088 - RXT-096 (Version 3)

POS.	Part #	Description	Qty
102	RX0701L-80	Rod- Tailgate RXT-080 Left	1
102	RX0701L-88	Rod- Tailgate RXT-088 Left	1
102	RX0701L-96	Rod- Tailgate RXT-096 Left	1
103	RX0708	Rod Tube - Nylon	1
104	RX0702-80	Tailgate- RXT-080	1
104	RX0702-88	Tailgate- RXT-088	1
104	RX0702-96	Tailgate- RXT-096	1
105	BM1217525	Bolt- M12 x 1.75 x 25	4
106	RX0702	Bracket- Tailgate Spring	2
107	RX0703	Rod- Tailgate Spring	2
108	RX0701	Bushing- Tailgate	2
109	BM1217570	Bolt- M12 x 1.75 x 70	2
110	RX0707	Spring- Tailgate	4
111	RX0701R-80	Rod- Tailgate RXT-080 Right	1
111	RX0701R-88	Rod- Tailgate RXT-088 Right	1
111	RX0701R-96	Rod- Tailgate RXT-096 Right	1
113	RX0801	Stand	1
114	RX0802	Bracket- Stand	1
115	YT10660501	Pin	1
116	BM1217530	Bolt- M12 x 1.75 x 30	2
	RXTUGBC002	Gearbox Complete (Version 3)	
	147125	Complete PTO - Series 60 - M200 Slip Clutch	
	180-510-60	Friction Disc - 6 1/3"OD	
117	OP1415	Oil Plug- M14 x 1.5	

MODEL MODIFICATIONS

MODEL	VERSION	SERIAL RANGE
RXT-072	1	Up to 151254
RXT-080	1	Up to 161078
RXT-088	1	Up to 181098
RXT-096	1	Up to 171173
RXT-072	2	151235-151254
RXT-080	2	161073-161074
RXT-088	2	181099-181105
RXT-096	2	171163, 171160, 171161, 171174-171179
RXT-072	3	151255+
RXT-080	3	161079 +
RXT-088	3	181106 +
RXT-096	3	171180 +

Tar River Implement

BXV-075 - BXV-085 - BXV-094 - BXV-104

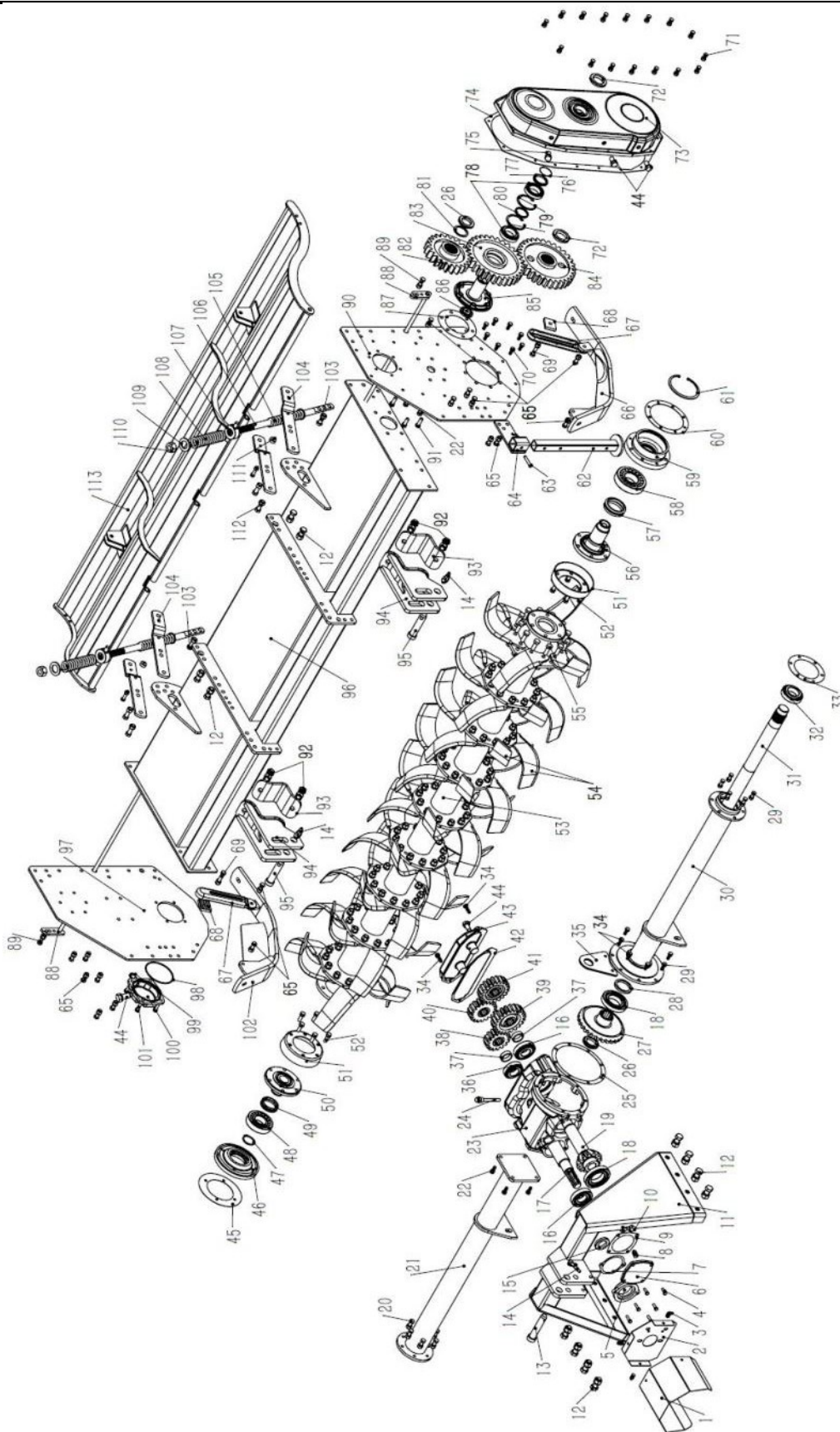

Tar River Implement
BXV-075 - BXV-085 - BXV-094 - BXV-104

POS.	Part #	Description	Qty
1	BV0317	PTO shield	1
2	BV0321	PTO shield support	1
3	BM812516	Bolt- M8 x 1.25 x 16	3
4	BM1012530	Bolt- M10 x 1.25 x 30	6
5	BV0320	Bearing support	1
6	BV0315	Gearbox cap	1
7	BV0318	Gasket - Input Shaft- M107 x 91 x 1	1
8	BM1012520	Bolt- M10 x 1.25 x 20	1
9	BV0314	Gasket Bearing Cover- M150 x 112 x 1	1
10	BV0408	Spacer- Right Rotor Support- M63 x 50 x 4	1
11	BV0101	A Frame	1
12	BM161540	Bolt- M16 x 1.5 x 40	12
13	BV0103	Top Hitch Pin	1
14	SB100756	Lynch Pin- M10mm	3
15	OS406210	Oil Seal- M40 x 62 x 10	1
16	B30308JR	Bearing- 30308JR	2
17	BV0319	Input Shaft	1
18	B30212JR	Bearing- 30212JR	2
19	BV0316	Pinion Shaft	1
20	BM1012535	Bolt- M10 x 1.25 x 35	6
21	BV0301-75	Gearbox Support Tube BXV-076	-
	BV0301-85	Gearbox Support Tube BXV-086	-
	BV0301-94	Gearbox Support Tube BXV-094	-
	BV0301-104	Gearbox Support Tube BXV-104	-
22	BM1212530	Bolt- M12 x 1.25 x 30	5
23	BV0313	Housing -Gearbox	1
24	BV0323	Dip Stick	1
25	BV0309	Gasket - Center Gearbox Left Side 240 x 206 x0.5	1
26	NM4515	Nut 45 x 1.5	2
27	BV0324	Ring Gear	1
28	OS607508	Oil Seal- M60 x 75 x 8	1
29	BM1012530	Bolt- M10 x 1.25 x 30	12
30	BV0310-75	Gearbox Shaft Tube Housing - BXV-076	-
	BV0310-85	Gearbox Shaft Tube Housing - BXV-086	-
	BV0310-94	Gearbox Shaft Tube Housing - BXV-094	-
	BV0310-104	Gearbox Shaft Tube Housing - BXV-104	-
31	BV0311-75	Drive Shaft -BXV-076	-
	BV0311-85	Drive Shaft -BXV-086	-
	BV0311-94	Drive Shaft -BXV-094	-
	BV0311-104	Drive Shaft -BXV-104	-
32	B32210JR	Bearing- 32210JR	1
33	BV0312	Gasket Drive Shaft-162 x 111 x 1	1

Tar River Implement

BXV-075 - BXV-085 - BXV-094 - BXV-104

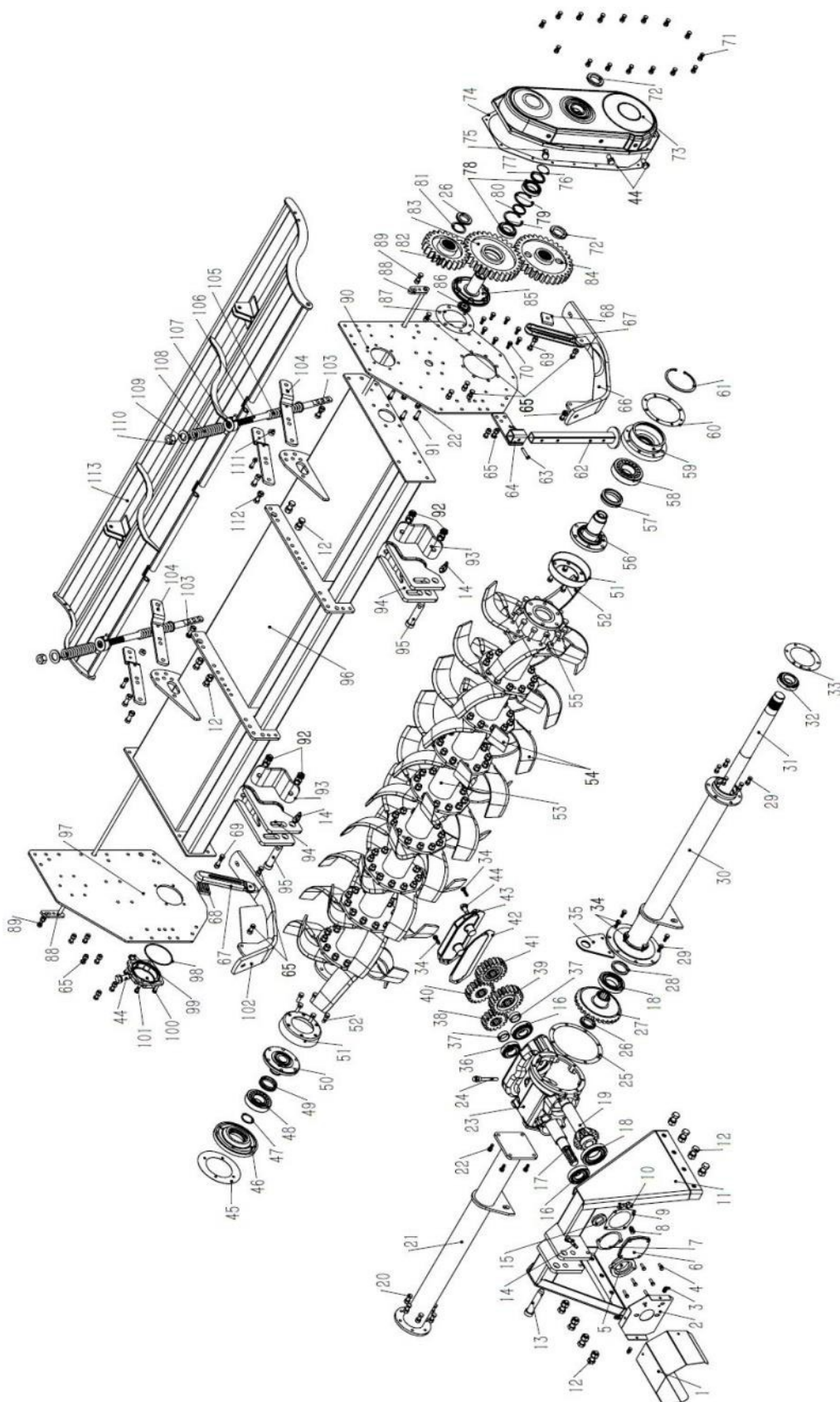

Tar River Implement
BXV-075 - BXV-085 - BXV-094 - BXV-104

POS.	Part #	Description	Qty
34	BM1U12535	BOIT 1U X 1.25 X 35	4
35	BV0322	Gearbox Lift Bracket	1
36	B32208JR	Bearing 32208JR	1
37	BV0308	Spacer—Exchange Gear 48 x 40x15	2
38	BV0304	Exchange Gear Z16	1
39	BV0307	Exchange Gear Z22	1
40	BV0303	Exchange Gear Z18	1
41	BV0306	Exchange Gear Z20	1
42	BV0302	Gasket - Rear Cover	1
43	BV0305	Rear Cover	1
44	OP1615	Oil Plug 16 x 1.5	4
45	BV0407	Gasket - Right Rotor 192 x 118 x 1	1
46	BV0406	Support - Bearing Right Rotor	1
47	SRE-50	Snap Ring 50 - External	1
48	B20310C	Bearing 20310C	1
49	OSFH0610	FH0610 Floating Seal	1
50	BV0405	Rotor Support Shaft - Right	
51	BV0403	Rotor Shield	2
52	BM1212535	Bolt 12 x 1.25 x 35	12
53	BV0401 - 75	Rotor Shaft - BXV-075	1
	BV0401 - 85	Rotor Shaft - BXV-085	
	BV0401 - 94	Rotor Shaft - BXV-094	
	BV0401 - 104	Rotor Shaft - BXV-104	
54	BV0210R	Tiller Tine - Right	24-27-30-33
	BV0210L	Tiller Tine - Left	24-27-30-33
55	BM141540	Bolt 14 x 1.5 x 40 Fine Thread	96-108-120-132
	LW14	Lock Washer 14mm	96-108-120-132
	NM140001	Nut 14mm Fine Thread	96-108-120-132
56	BV0402	Rotor Support Shaft - Left	1
57	OSH0720A	FH0720A Floating Seal	1
58	B213120	Bearing 213120	1
59	BV0401	Bearing support	1
60	BV0511	Gasket—Left Rotor 194 x 150 x 1	1
61	SRI-130	Snap Ring 130 - Internal	1
62	BV0702	Stand	1
63	BV0703	Lynch Pin 10x55	1
64	BV0701	Bracket - Stand	1
65	BM1212535	Bolt 12 x 1.25 x 35	16
66	BV0902	Skid Weldment -left	1

Tar River Implement

BXV-075 - BXV-085 - BXV-094 - BXV-104

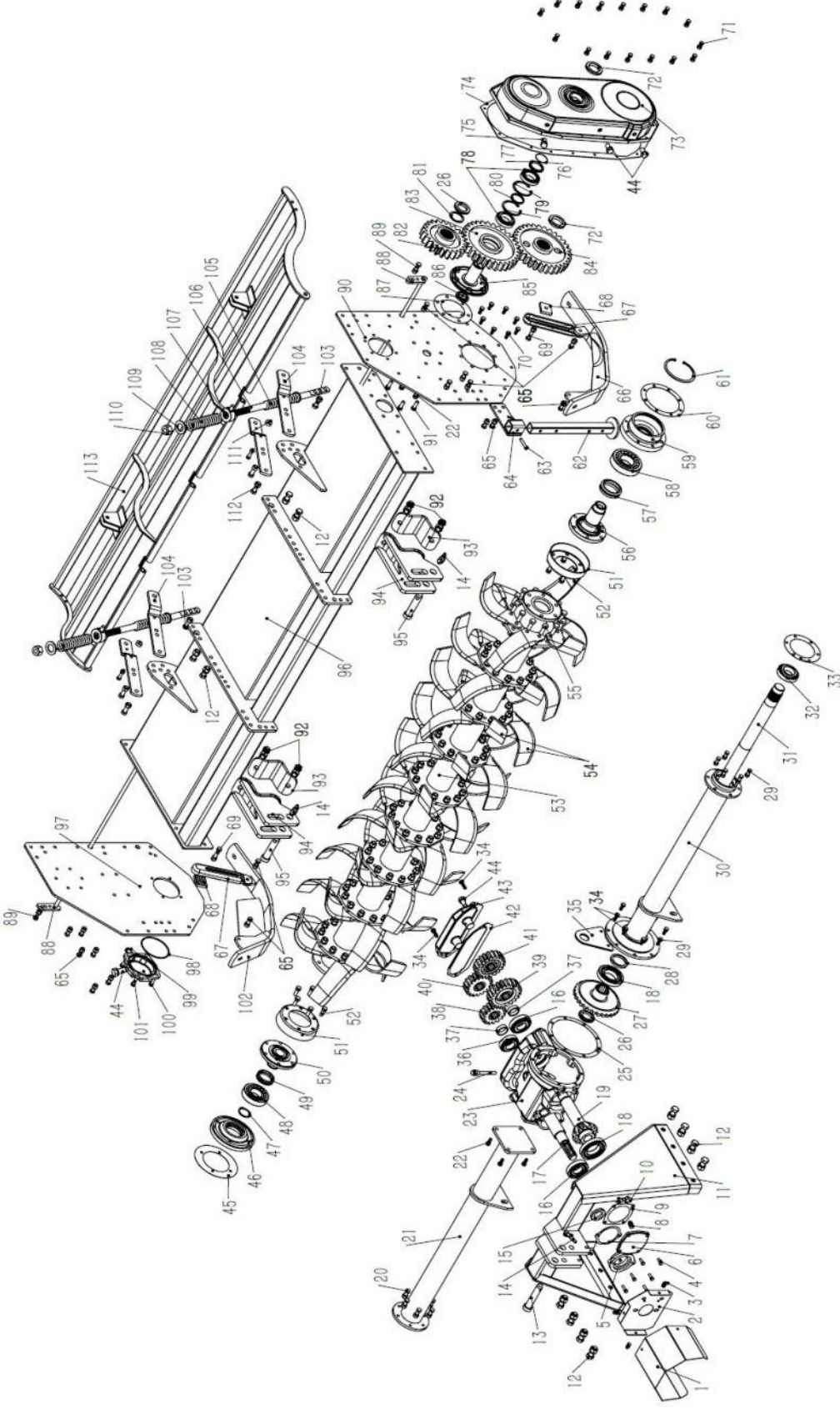

Tar River Implement
BXV-075 - BXV-085 - BXV-094 - BXV-104

POS.	Part #	Description	Qty
67	BV0801	Skid Adjustment Bracket	2
68	BV0802	Skid Adjustment Stop	2
69	BM1212560	Bolt- M12 x 1.25 x 60	2
70	BM1012525	Bolt- M10 x 1.25 x 25	8
71	BM1012525	Bolt- M10 x 1.25 x 25	14
72	SNM50150	Spanner Nut- M50 x 1.5	2
73	BV0500	Gear Cover	1
74	BV0507	Gasket- Gear Cover	1
75	UP1615B	Breatner Cap- M16 x 1.5	1
76	OR50x18	O-Ring- M50 x 1.8	1
77	BV0503	Spacer- Idler Gear- M63.5 x 50 x 6.5	1
78	B32010JR	Bearing- 32010JR	
79	SRI-80	Snap Ring- Internal- M80	2
80	BV0505	Gasket- Center Gear- M57 x 50 x 5	1
81	BV0506	Spacer- Top Gear- M63 x 50 x 2	1
82	BV0508	Gear- Top- Z-23	1
83	BV0502	Gear- Idler- Z-31	1
84	BV0501	Gear- Bottom- Z-31	1
85	BV0510	Idler Gear Hub	1
86	LNM3515	Self-locking Nut- M35 x 1.5	1
87	BV0509	Gasket- Idler Gear hub- M170 x 140 x 1	1
88	BV0605-75	Rod- Tail Gate- BXV-075	2
	BV0605-85	Rod- Tail Gate- BXV-085	2
	BV0605-94	Rod- Tail Gate- BXV-094	2
	BV0605-104	Rod- Tail Gate- BXV-0104	2
89	BM1212545	Bolt- M12 x 1.25 x 45	2
90	BV0506	Side Board- Left	1
91	BM1212540	Bolt- M12 x 1.25 x 40	4
92	BM181550	Bolt- M18 x 1.5 x 50	4
93	BV0204	Hitch Block Support	2
94	BV0203	Lower Hitch Block	2
95	BV0205	Lower Hitch Pin	2
96	BV0201-75	Main Frame - BXV-075	1
	BV0201-85	Main Frame - BXV-085	1
	BV0201-94	Main Frame - BXV-094	1
	BV0201-104	Main Frame - BXV-104	1
97	BV0202	Side Board - Right	1
98	OR118355	O-Ring- M118 x 3.55	1
99	OP12125	Oil Plug- M12 x 1.25	1

Tar River Implement

BXV-075 - BXV-085 - BXV-094 - BXV-104

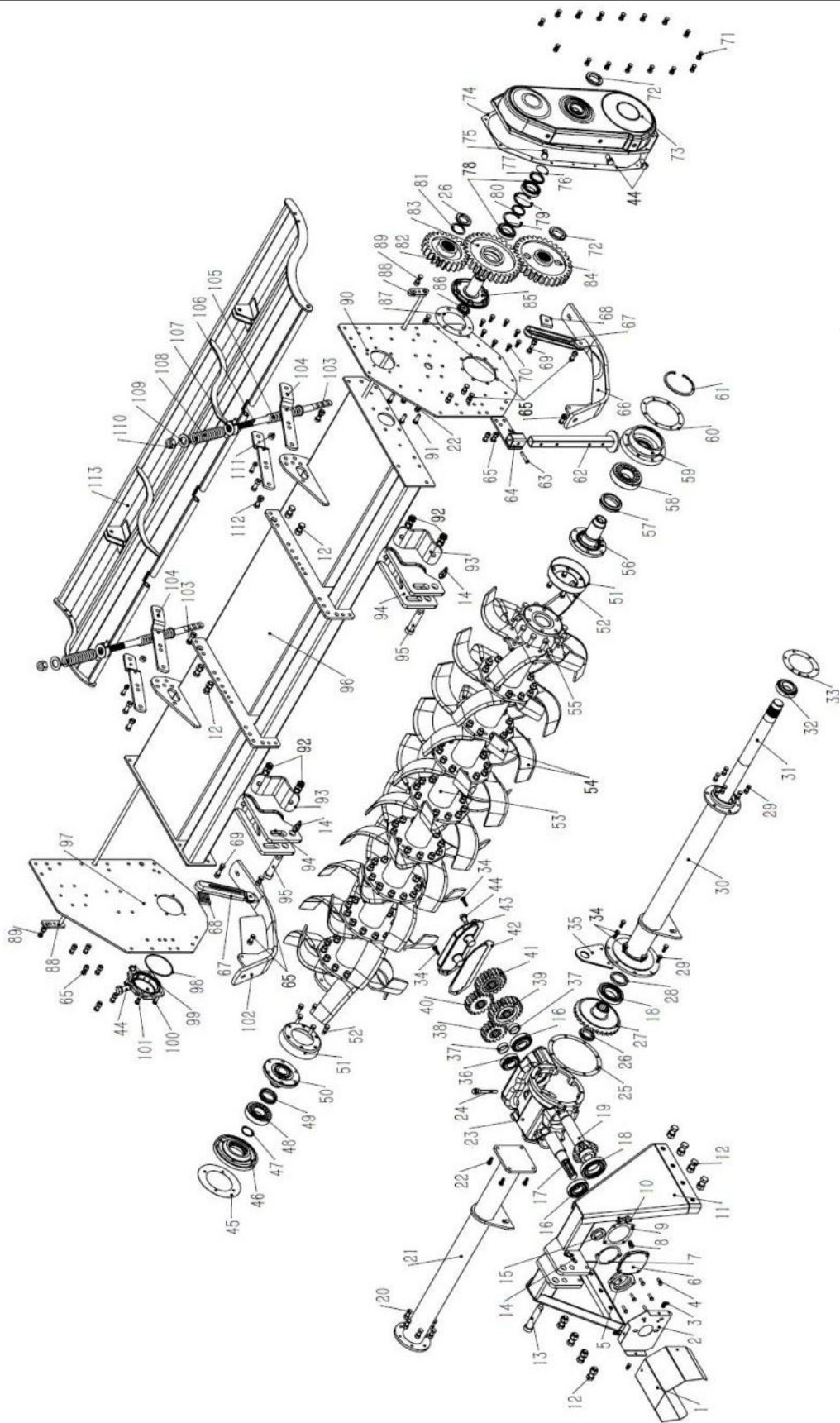

Tar River Implement
BXV-075 - BXV-085 - BXV-094 - BXV-104

POS.	Part #	Description	Qty
100	BV0409	Rotor Cap	1
101	BM1212540	Bolt- M12 x 1.25 x 40	4
102	BV0901	Skid Weldment- Right	1
103	BM1012545	Bolt- M10 x 1.25 x 45	2
104	BV0603	Bracket- Tailgate Spring	4
105	BV0609	Lower Spring- Tailgate- M184	2
106	BV0605	Rod- Tailgate	2
107	BV0606	Spring Bushing	2
108	BV0601	Upper Spring- Tailgate- M175	2
109	FW24	Flat Washer- M24	2
110	LNM2415	Self Locking Nut- M24 x 1.5	2
111	BV0604	Spacer- Tailgate Brackets- M26 x 10.5 x 10	2
112	BM141545	Bolt- M14 x 1.5 x 45	6
113	BV0602-075	Tailgate- BXV-075	1
	BV0602-085	Tailgate- BXV-085	1
	BV0602-094	Tailgate- BXV-094	1
	BV0602-104	Tailgate- BXV-104	1
	147127	Complete PTO - Series 80 - 200mm Slip Clutch	
	180-510-60	Friction Disc - 6 1/3"OD	

Tar River Implement

CXT (Version 1)

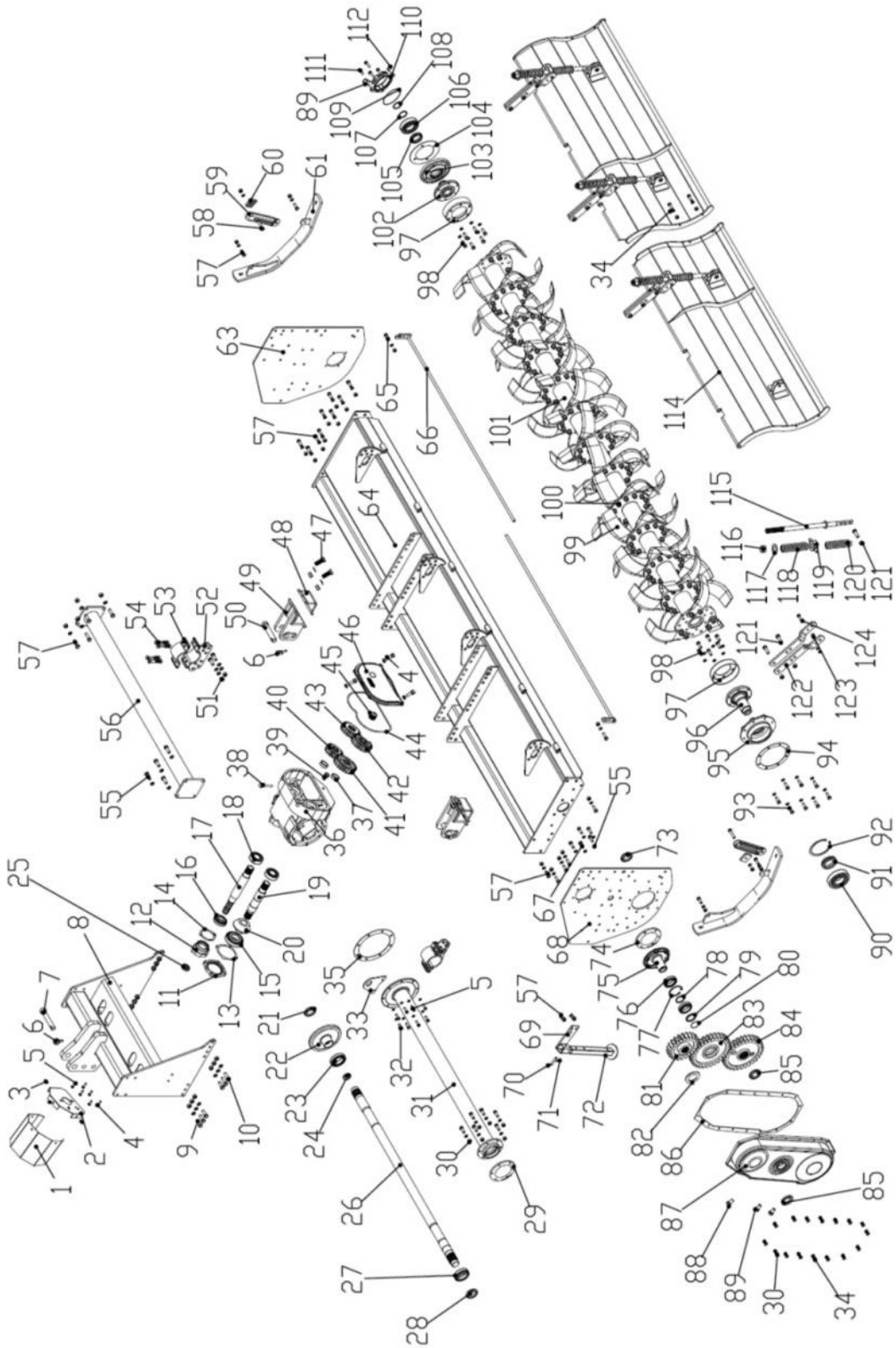

Tar River Implement

CXT (Version 1)

POS.	Part #	Description	Qty
1	BV0317	PTO shield	1
2	BV0321	PTO shield support	1
3	BM812516	Bolt- M8 x 1.25 x 16	3
4	BM1012535	Bolt- M10 x 1.25 x 35	7
5	BM1012535	Bolt- M10 x 1.25 x 35	4
6	LYNPN10	Lynch Pin- M10	3
7	BV0103	Top Hitch Pin	1
8	CX0101	A-Frame	1
9	BM141540	Bolt- M14 x 1.5 x 40	8
10	BM141545	Bolt- M14 x 1.5 x 45	4
11	CX0315	Bearing Cap- Pinion Shaft	1
12	CX0320	Cap- Input Shaft	1
13	CX0314	Gasket- Pinion shaft	1
14	CX0318	Gasket- Input Shaft	1
15	B31310	Bearing- 31310	1
16	B30208	Bearing- 30208	1
17	CX0319	Input Shaft	1
18	B33208	Bearing- 33208	2
19	CX0316	Pinion Shaft	1
20	CX0323	Pinion Gear	1
21	NM4515	Nut- M45 x 1.5	1
22	CX0322	Ring Gear	1
23	B32012	Bearing- 32012	1
24	OS60758	Oil Seal- M60 x 75 x 8	1
25	OS406210	Oil Seal- M40 x 62 x 10	1
26	CX0311-076	Drive Shaft CXT-076	1
	CX0311-086	Drive Shaft CXT-086	1
	CX0311-095	Drive Shaft CXT-095	1
	CX0311-104	Drive Shaft CXT-104	1
	CX0311-112	Drive Shaft CXT-112	1
	CX0311-121	Drive Shaft CXT-121	1
27	B32210	Bearing- 32210	1
28	NM4515	Nut- M45 x 1.5	1
29	BV0312	Gasket - Drive Tube Outer	1
30	BM1012530	Bolt- M10 x 1.25 x 30	20
31	CX0310-076	Drive Shaft Tube Housing - CXT-076	1
	CX0310-086	Drive Shaft Tube Housing - CXT-086	1
	CX0310-095	Drive Shaft Tube Housing - CXT-095	1
	CX0310-104	Drive Shaft Tube Housing - CXT-104	1
	CX0310-112	Drive Shaft Tube Housing - CXT-112	1
	CX0310-121	Drive Shaft Tube Housing - CXT-121	1

Tar River Implement

CXT (Version 1)

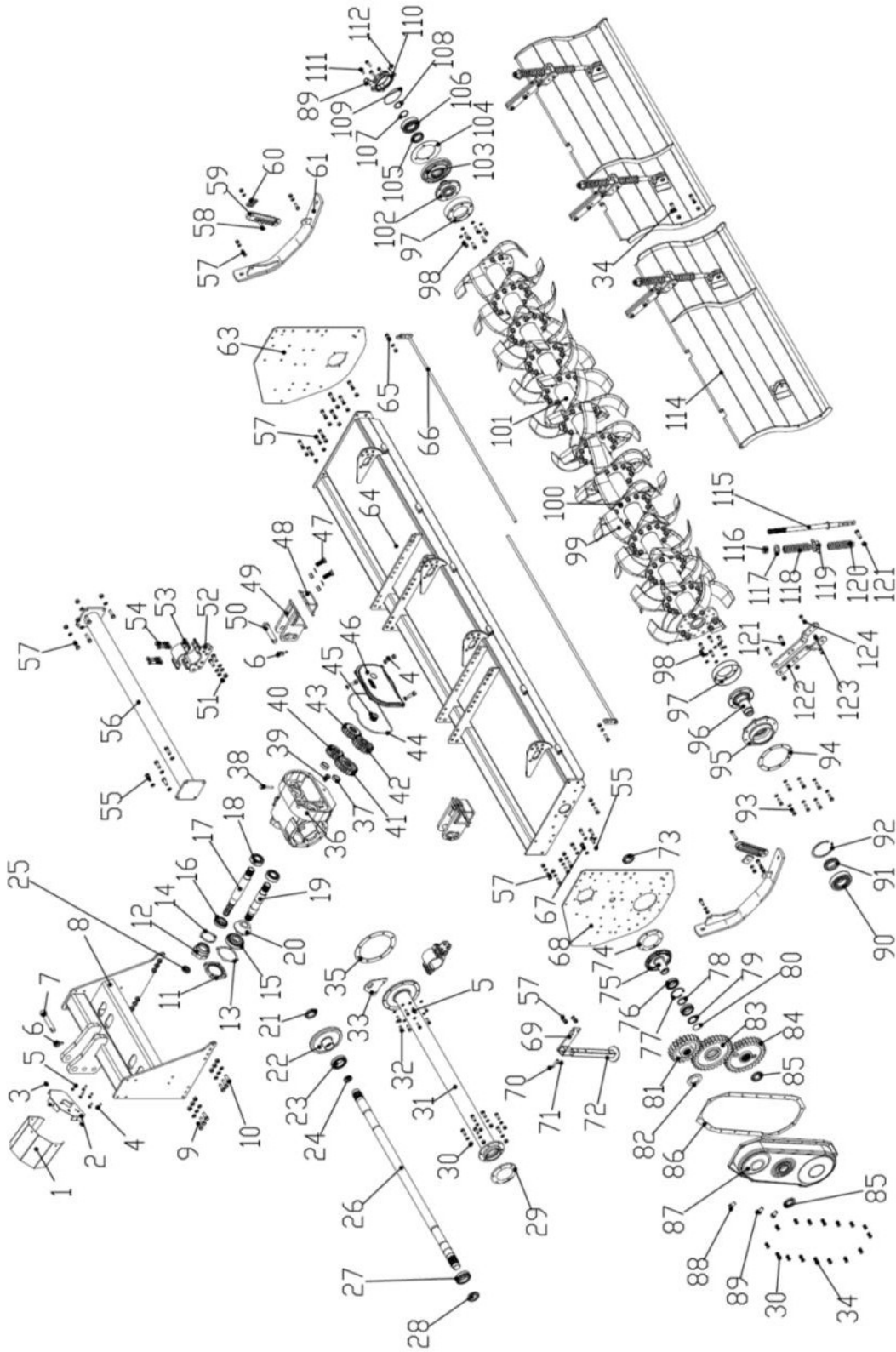

Tar River Implement

CXT (Version 1)

POS.	Part #	Description	Qty
32	BM1012530	Bolt- M10 x 1.25 x 30	6
33	BV0322	Gearbox Lift Bracket	1
34	BM1012535	Bolt- M10 x 1.25 x 35	4
35	CX0309	Gasket- Drive Tube- Inner	1
36	CX0313	Gearbox Housing	1
37	CX0308	Spacer- Exchange Gear	2
38	YT10660303000	Dipstick	1
39	OP1415	Oil Plug- M14 x 1.5	1
40	CX0304	Exchange Gear Z17	1
41	CX0303	Exchange Gear Z23	1
42	CX0307	Exchange Gear Z21	1
43	CX0306	Exchange Gear Z19	1
44	CX0302	Gasket Rear Cover	1
45	CX0312	Gear Shaft	1
46	CX0305	Gearbox Cover	1
47	BM151550	Bolt- M18 x 1.5 x 50	4
48	BX0207	Hitch Block Support	2
49	CX0205	Hitch Block	2
50	CX0204	Lower Hitch Pin - Cat. 2	2
51	BM1412540	Bolt- M14 x 1.50 x 40	4
52	CX0203	Tube Support - Lower	2
53	CX0202	Tube Support - Upper	2
54	BM1212540	Bolt- M12 x 1.25 x 40	8
55	BM1212530	Bolt- M12 x 1.25 x 30	5
56	CX0301-076	Gearbox Support Tube- CXT-076	1
	CX0301-086	Gearbox Support Tube- CXT-086	1
	CX0301-095	Gearbox Support Tube- CXT-095	1
	CX0301-104	Gearbox Support Tube- CXT-104	1
	CX0301-110	Gearbox Support Tube- CXT-112	1
	CX0301-121	Gearbox Support Tube- CXT-121	1
57	BM1212535	Bolt- M12 x 1.25 x 35	24
58	BM1212560	Bolt- M12 x 1.25 x 60	2
59	BX0802	Skid Adjustment Stop	2
60	BX0801	Skid Adjustment Bracket	2
61	BV0901	Skid Weldment - Right	1
62	BV0801	Skid Weldment - Left	1
63	CX0201	Side Board-Right	1
64	CX300-076	Main Frame- CXT-076	1
	CX300-086	Main Frame- CXT-086	1
	CX300-095	Main Frame- CXT-095	1
	CX300-104	Main Frame- CXT-104	1
	CX300-112	Main Frame- CXT-112	1
	CX300-121	Main Frame- CXT-121	1
65	BM1212545	Bolt- M12 x 1.25 x 45	2

Tar River Implement

CXT (Version 1)

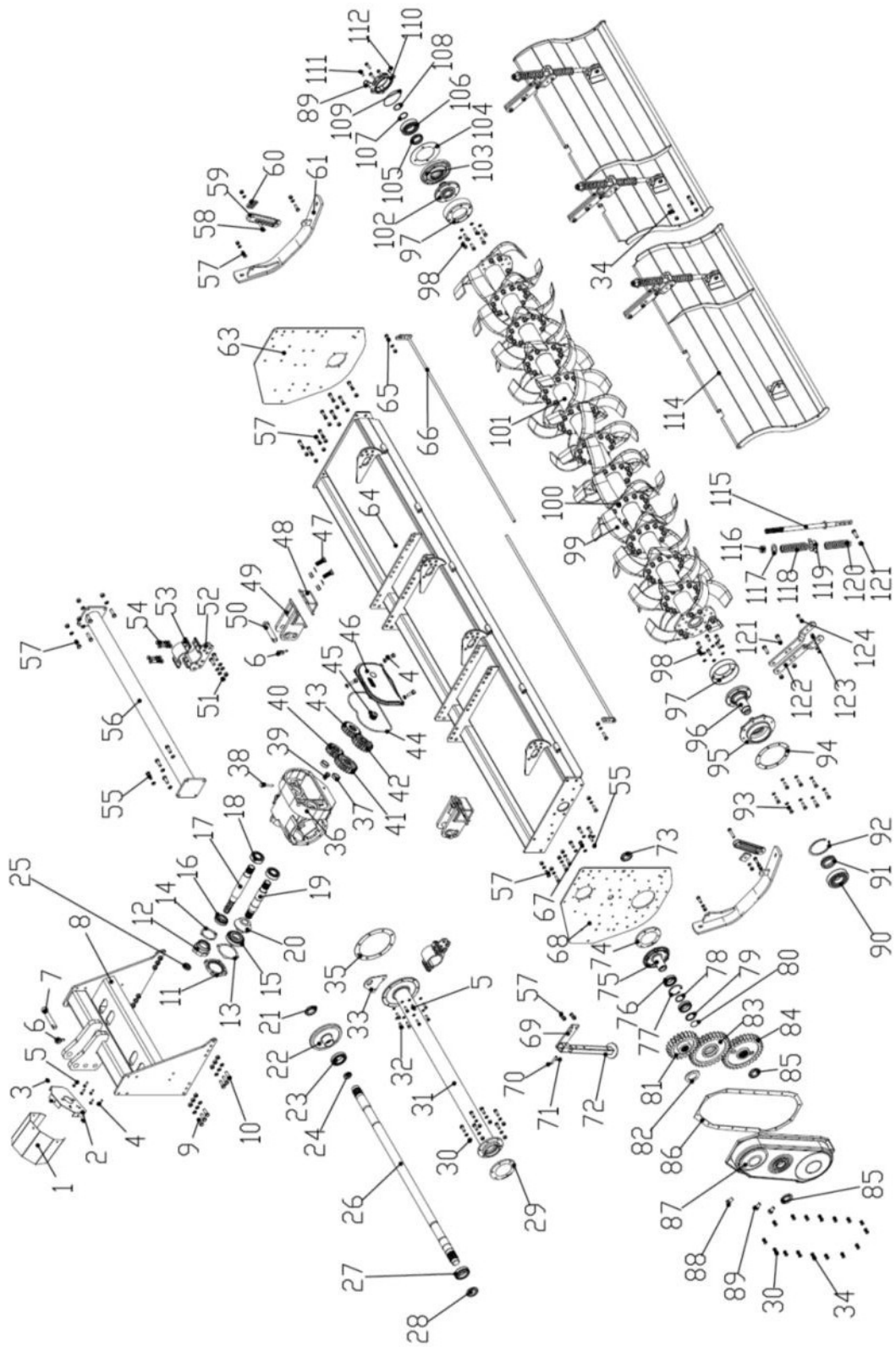

Tar River Implement

CXT (Version 1)

POS.	Part #	Description	Qty
66	CX0603-076	Rod Tailgate- CXT-076	2
	CX0603-086	Rod Tailgate- CXT-086	2
	CX0603-095	Rod Tailgate- CXT-095	2
	CX0603-104	Rod Tailgate- CXT-104	2
	CX0603-112	Rod Tailgate- CXT-112	2
	CX0603-121	Rod Tailgate- CXT-121	2
67	BM1212540	Bolt- M12 x 1.25 x 40	4
68	BV0506	Side Board- Left	1
69	BV0701	Bracket- Stand	1
70	LYNPN10	Lynch Pin- M10 x 55	1
71	RC3	R-Clip- M3	1
72	BV0702	Stand	1
73	NM3515	Nut- M35 x 1.5	1
74	BV0509	Gasket- Idler Gear Hub- M170 x 140 x 1	1
75	BV0510	Idler Gear Hub	1
76	B32010	Bearing- 32010	2
77	SRI-80	Snap Ring- Internal- M80	2
78	BV0504	Spacer- M63 x 50 x 2	1
79	BV0503	Idler Gear Spacer- M63.5 x 50 x 6.5	1
80	OR50x1.8	O Ring- M50 x 1.8	1
81	BV0508	Gear- Top- Z23	1
82	BV0506	Top Gear Spacer- M63 x 50 x 2	1
83	BV0502	Gear- Idler- Z31	1
84	BV0501	Gear- Bottom- Z31	1
85	SNM50150	Spanner Nut- M50 x 1.5	2
86	BV0507	Gasket - Gear Cover	1
87	BV0500	Gear Cover	1
88	OP1615V	Breather Cap- M16 x 1.5	1
89	OP1615	Oil Plug- M16 x 1.5	3
90	B6312	Bearing- 6312	1
91	OSHF0720A	Oil Seal- HF0720A	1
92	SRI-130	Snap Ring- Internal- M130	1
93	BM1012525	Bolt 10 x 1.25 x 25	8
94	CX0511	Gasket- Left Rotor	1
95	CX0401	Bearing support	1
96	BV0402	Rotor Support Shaft - Left	1
97	BV0403	Rotor Shield	2
98	BM1212535	Bolt- M12 x 1.25 x 35	12
99	BV0210R	Tiller Tine- Right	-
	BV0210L	Tiller Tine- Left	-
100	BM141540	Bolt- M14 x 1.5 x 40	-

Tar River Implement

CXT (Version 1)

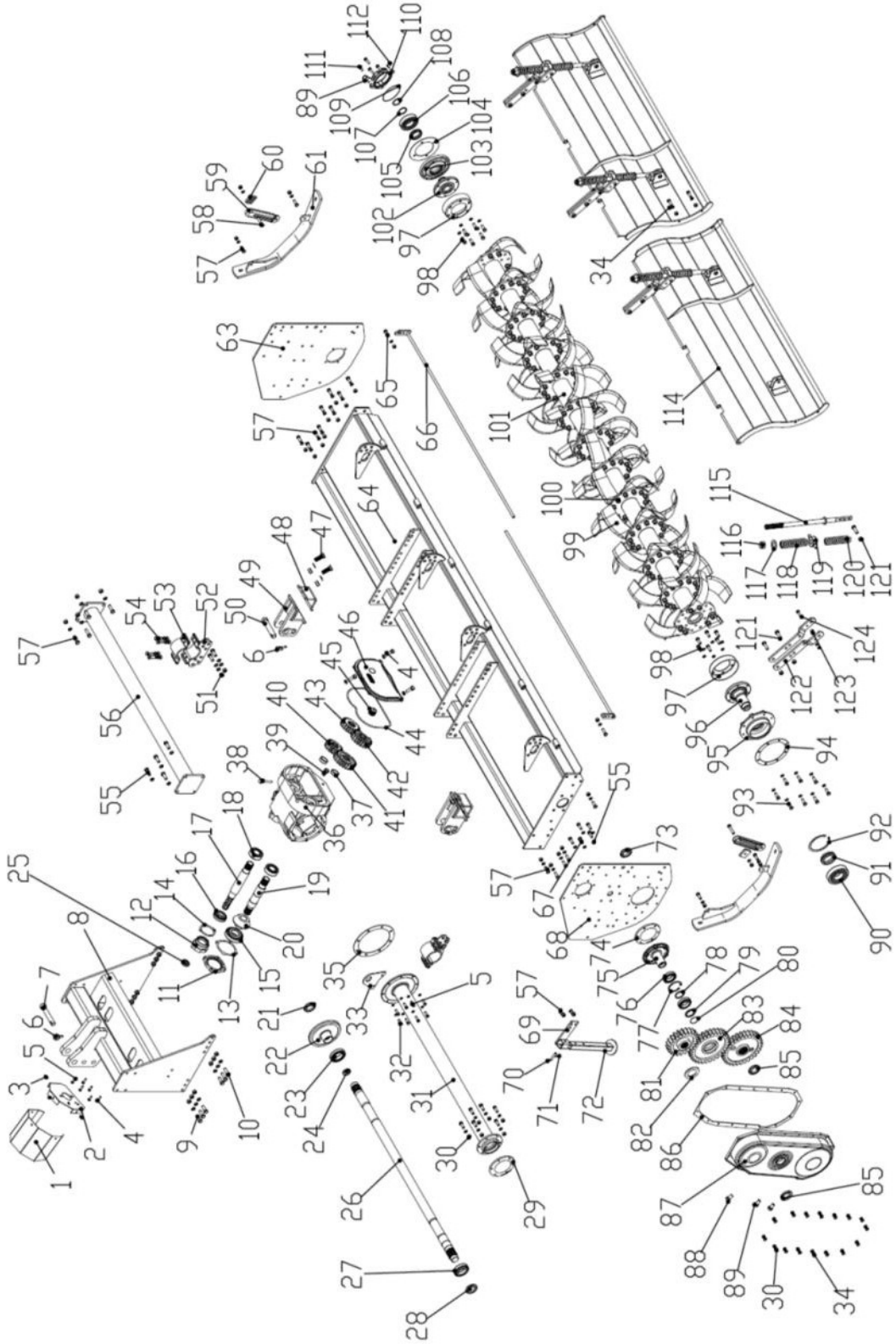

Tar River Implement

CXT (Version 1)

POS.	Part #	Description	Qty
101	CX0401-076	Rotor Shaft- CXT-076	1
	CX0401-086	Rotor Shaft- CXT-086	1
	CX0401-095	Rotor Shaft- CXT-095	1
	CX0401-104	Rotor Shaft- CXT-104	1
	CX0401-112	Rotor Shaft- CXT-112	1
101	CX0401-121	Rotor Shaft- CXT-121	1
102	BV0405	Rotor Support Shaft- Right	1
103	BV0406	Bearing Support	1
104	BV0407	Gasket- M192 x 118 x 1	1
105	OSHP0610	Oil Seal- HP0610	1
106	B6310	Bearing- 6310	1
107	BV0408	Spacer- Rotor Support- Right- M63 x 50 x 4	1
108	SRE-50	Snap Ring- External- M50	1
109	OR118x3.55	O-Ring- M118 x 3.55	1
110	BV0409	Rotor Cap	1
111	BM1212540	Bolt- M12 x 1.25 x 40	4
112	OP12125	Oil Plug- M12 x 1.25	1
114	CX0601-076R	Tailgate- Right- CXT-076	1
	CX0601-076L	Tailgate- Left- CXT-076	1
	CX0601-086R	Tailgate- Right- CXT-086	1
	CX0601-086L	Tailgate- Left- CXT-086	1
	CX0601-095R	Tailgate- Right- CXT-095	1
	CX0601-095L	Tailgate- Left- CXT-095	1
	CX0601-104R	Tailgate- Right- CXT-104	1
	CX0601-104L	Tailgate- Left- CXT-104	1
	CX0601-112R	Tailgate- Right- CXT-112	1
	CX0601-112L	Tailgate- Left- CXT-112	1
	CX0601-121R	Tailgate- Right- CXT-121	1
	CX0601-121L	Tailgate- Left- CXT-121	1
115	BV0605	Rod- Tailgate	2
116	LN24	Self-locking Nut- M24	4
117	FW24	Flat Washer- M24	4
118	BV0601	Upper Spring- Tailgate- M175	4
119	BV0606	Spring Bushing	4
120	BV0609	Lower Spring- Tailgate- M184	4
121	BM141545	Bolt- M14 x1.5 x 45	12
122	BV0603	Bracket- Tailgate Spring	8
123	BV0604	Spacer- Tailgate Brackets- M26 x 10.5 x 10	4
124	BM1012545	Bolt- M10 x 1.25 x 45	4
	CXTGBC001	Gearbox Complete- with exchange gears	
	147127	Complete PTO - Series 80 - M200 Slip Clutch	
	180-510-60	Friction Disc - 6 1/3"OD	

Tar River Implement

CXT (Version 2)

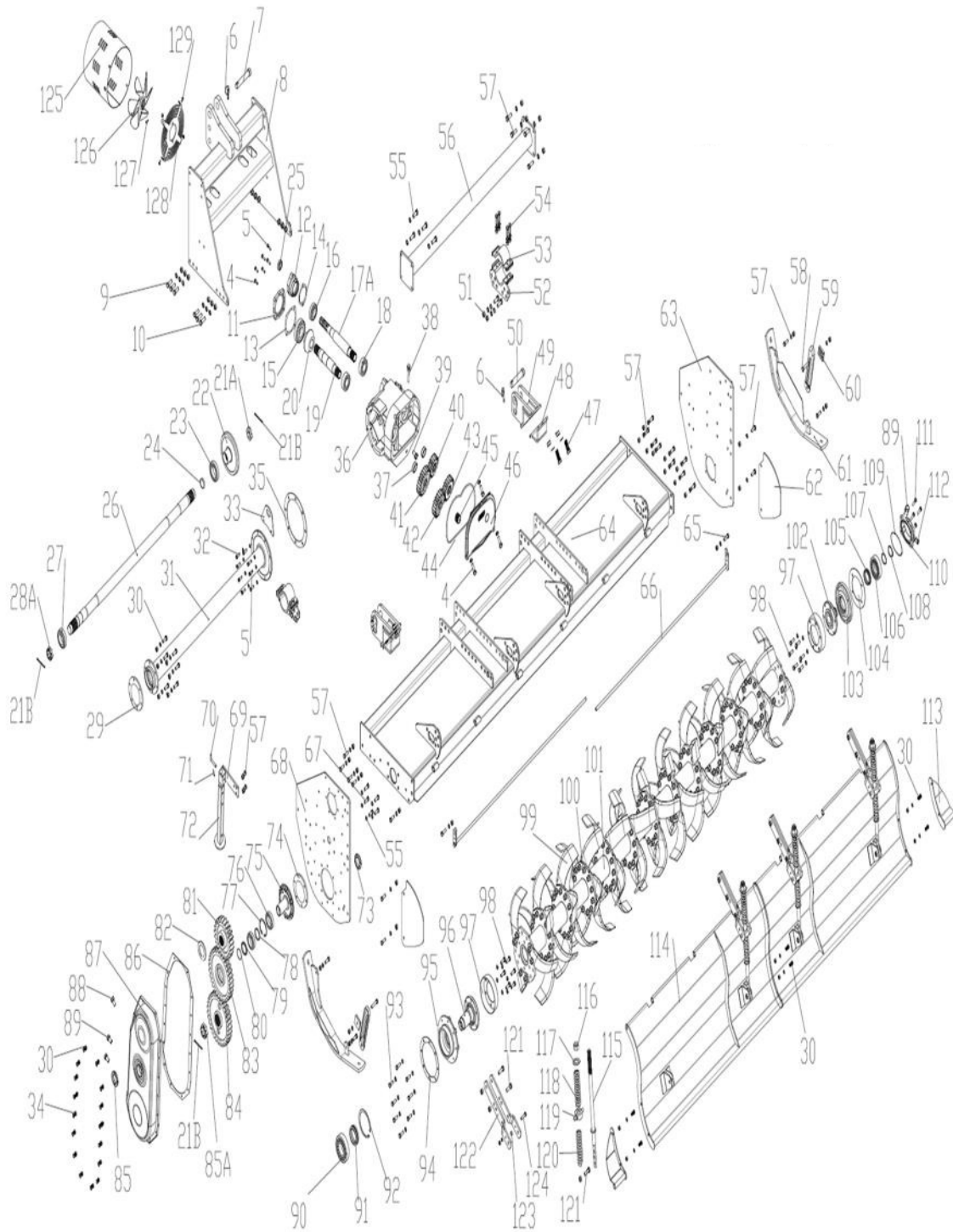

Tar River Implement

CXT (Version 2)

POS.	Part #	Description	Qty
1	N/A		
2	N/A		
3	N/A		
4	BM1012535	Bolt- M10 x 1.25 x 35	7
5	BM1012535	Bolt- M10 x 1.25 x 35	4
6	LYNPN10	Lynch Pin- M10	3
7	BV0103	Top Hitch Pin	1
8	CX0101	A Frame	1
9	BM141540	Bolt- M14 x 1.5 x 40	8
10	BM141545	Bolt- M14 x 1.5 x 45	4
11	CX0315	Bearing Cap- Pinion Shaft	1
12	CX0320	Cap- Input Shaft	1
13	CX0314	Gasket-Pinion Shaft	1
14	CX0318	Gasket - Input Shaft	1
15	B31310	Bearing- 31310 (HRB)	1
16	B31208	Bearing- 30208 (HRB)	1
17	CX0319A	Input Shaft	1
18	B33208	Bearing- 33208 (HRB)	2
19	CX0316	Pinion Shaft	1
20	CX0323	Pinion Gear	1
21A	SNM4515	Spanner Nut- M45 x 1.5	1
21B	CP5x80	Cotter Pin- M5 x 80	
22	CX0322	Ring Gear	1
23	B32012	Bearing- 32012 (HRB)	1
24	OS607508	Oil Seal- M60 x 75 x 8	1
25	OS406210	Oil Seal- M40 x 62 x 10	1
26	CX0311-086	Drive Shaft- CXT-086	1
	CX0311-095	Drive Shaft- CXT-095	1
	CX0311-104	Drive Shaft- CXT-104	1
	CX0311-112	Drive Shaft- CXT-112	1
	CX0311-121	Drive Shaft- CXT-121	1
27	B32210	Bearing- 32210 (HRB)	1
28	NM4515	Nut- M45 x 1.5	1
29	BV0312	Gasket- Drive Tube Outer	
30	BM1012530	Bolt- M10 x 1.25 x 30	20
31	CX0310-086	Gearbox Shaft Tube Housing- CXT-086	1
	CX0310-095	Gearbox Shaft Tube Housing- CXT-095	1
	CX0310-104	Gearbox Shaft Tube Housing- CXT-104	1
	CX0310-112	Gearbox Shaft Tube Housing- CXT-112	1
	CX0310-121	Gearbox Shaft Tube Housing- CXT-121	1
32	BM1012530	Bolt- M10 x 1.25 x 30	6
33	BV0322	Gearbox Lift Bracket	1

Tar River Implement

CXT (Version 2)

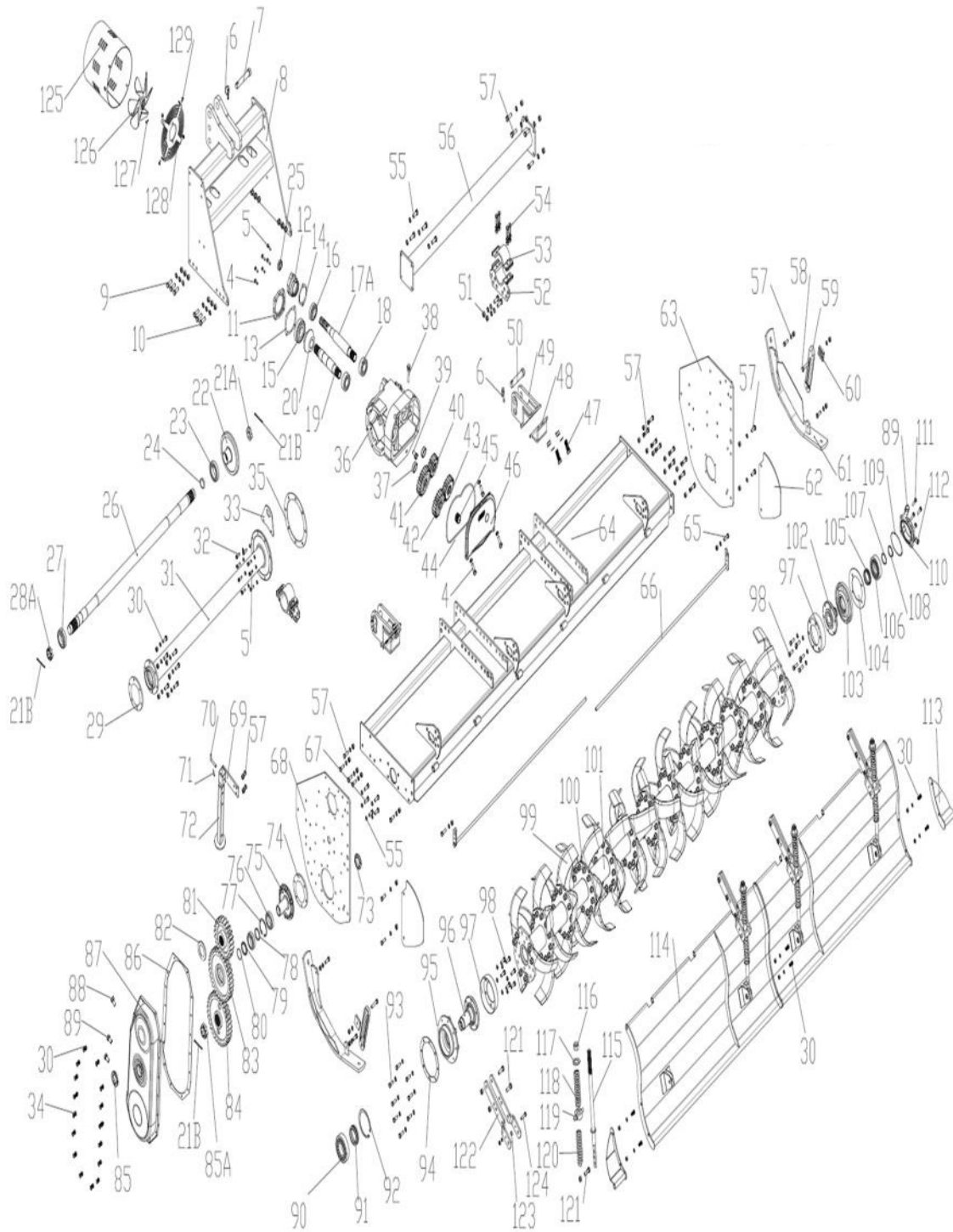

Tar River Implement

CXT (Version 2)

POS.	Part #	Description	Qty
34	BM1012530	Bolt- M10 x 1.25 x 30	20
35	CX0309	Gasket- Drive Tube- Inner	1
36	CX0313	Gearbox Housing	1
37	CX0308	Spacer (Exchange Gear)	2
38	YT10660303000	Dip Stick	1
39	OP1415	Oil Plug- M14X1.5	1
40	CX0304	Exchange Gear- Z17	1
41	CX0303	Exchange Gear- Z23	1
42	CX0307	Exchange Gear- Z21	1
43	CX0306	Exchange Gear- Z19	1
44	CX0302	Gasket Rear Cover	1
45	CX0312	Gear Shaft	1
46	CX0305	Gearbox Cover	1
47	BM181550	Bolt- M18 x 1.5 x 50	4
48	BX0207	Hitch Block Support	2
49	CX0205	Hitch Block	2
50	CX0204	Lower Hitch Pin- Cat.2	2
51	BM141540	Bolt- M14 x 1.5 x 40	4
52	CX0203	Tube Support-Lower	2
53	CX0202	Tube Support-Upper	2
54	BM1212540	Bolt- M12 x 1.25 x 40	8
55	BM1212530	Bolt- M12 x 1.25 x 30	5
56	CX0301-086	Gearbox Support Tube- CXT-086	1
	CX0301-095	Gearbox Support Tube- CXT-095	1
	CX0301-104	Gearbox Support Tube- CXT-104	1
	CX0301-112	Gearbox Support Tube- CXT-112	1
	CX0301-121	Gearbox Support Tube- CXT-121	1
57	BM1212535	Bolt- M12 x 1.25 x 35	24
58	BM1212560	Bolt- M12 x 1.25 x 60	2
59	BV0801	Skid Adjustment Bracket	2
60	BV0802	Skid Adjustment Stop	2
61	BV0901	Skid Weldment- Left	2
62	BV0509	Gasket- M170 x 140 x 1	2
63	CX0201	Side Board- Right	1
64	CX2050201	Main Frame- CXT-086	1
	CX2300201	Main Frame- CXT-095	1
	CX2600201	Main Frame- CXT-104	1
	CX2800202	Main Frame- CXT-112	1
	CX3000201	Main Frame- CXT-121	1
65	BM1212545	Bolt- M12 x 1.25 x 45	2

Tar River Implement

CXT (Version 2)

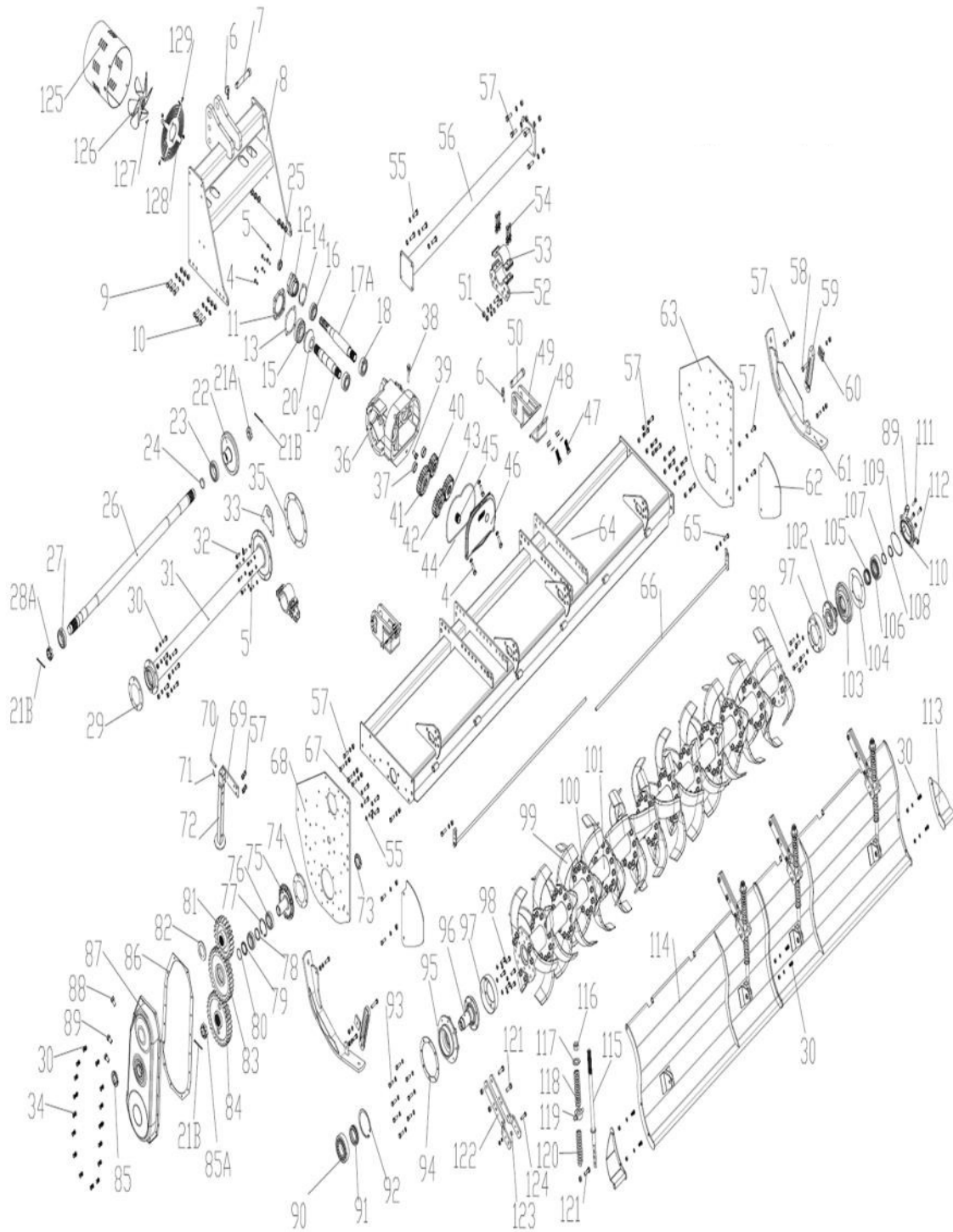

Tar River Implement

CXT (Version 2)

POS.	Part #	Description	Qty
66	CX0603-086	Rod- Tail Gate - CXT-086	2
	CX0603-095	Rod- Tail Gate - CXT-095	2
	CX0603-104	Rod- Tail Gate - CXT-104	2
	CX0603-112	Rod- Tail Gate - CXT-112	2
	CX0603-121	Rod- Tail Gate - CXT-121	2
67	BM1212540	Bolt- M12 x 1.25 x 40	4
68	BV0506	Side Board- Left	1
69	BV0701	Bracket- Stand	1
70	BV0703	Lynch Pin- M10 x 55	1
71	RC3000	R Clip- M3	1
72	BV0702	Stand	1
73	SNM3515	Spanner Nut- M35 x 1.5	1
74	BV0509	Gasket- Idler Gear hub	1
75	BV0510	Idler Gear Hub	1
76	B32010	Bearing- 32010	2
77	SRI-80	Snap Ring- Internal- M80	2
78	BV0504	Spacer- M63 x 50 x 2	1
79	BV0503	Spacer- Idler Gear- M63.5 x 50 x 6.5	1
80	OR5018	O-Ring- M50 x 1.8	1
81	BV0505	Gear- Top Z23	1
82	BV0506	Spacer- Top Gear- M63 x 50 x 2	1
83	BV0502	Gear- Idler Z31	1
84	BV0501	Gear- Bottom Z31	1
85	SLNM5015	Self Locking Spanner Nut- M50 x 1.5	1
85A	SNM5015	Spanner Nut- M50 x 1.5	1
86	BV0507	Gasket - Gear Cover	1
87	BV0501	Gear Cover	1
88	OP1615V	Breather Cap- M16 x 1.5	1
89	OP1615	Oil Plug- M16 x 1.5	3
90	B6312	Bearing- 6312	1
91	OSHF0720A	Oil Seal- HF0720A	1
92	SRI130	Snap Ring- Internal- M130	1
93	BM1012525	Bolt- M10 x 1.25 x 25	8
94	CX0511	Gasket - Left Rotor	1
95	CX0401	Bearing support	1
96	BV0402	Rotor Support Shaft - Left	1
97	BV0403	Rotor Shield	2
98	BM1212535	Bolt- M12 x 1.25 x 35	12
99	BV0210R	Tiller Tine- Right	78
	BV0210L	Tiller Tine- Left	78
100	BM141540	Bolt- M14 x 1.5 x 40	156
101	CX0401-086	Rotor Shaft- CXT-086	1

Tar River Implement

CXT (Version 2)

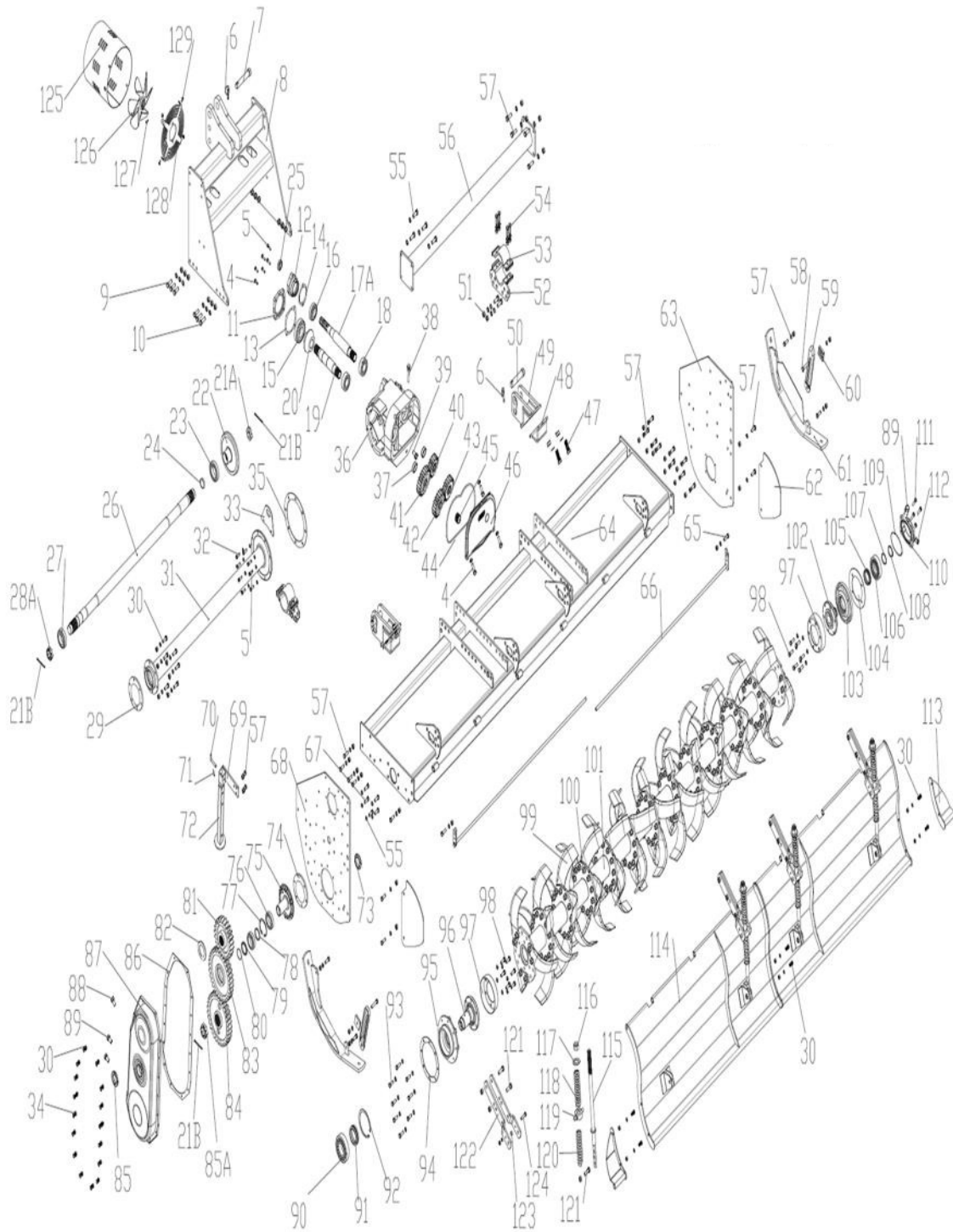

Tar River Implement

CXT (Version 2)

POS.	Part #	Description	Qty
	CX0401-095	Rotor Shaft- CXT- 095	1
	CX0401-104	Rotor Shaft- CXT-104	1
	CX0401-112	Rotor Shaft- CXT-112	1
	CX0401-121	Rotor Shaft- CXT-121	1
102	BV0405	Rotor Support Shaft- Right	1
103	BV0406	Support Bearing- Rotor- Right	1
104	BV0407	Gasket- Rotor- Right- M192 x 118 x 1	1
105	OSHF0610	Oil Seal- HF0610	1
106	B6310	Bearing- 6310 (HRB)	1
107	BV0408	Spacer- Rotor Support- Right- M63 x 50 x 4	1
108	SRE-50	Snap Ring- External- M50	1
109	OR118355	Oil Ring- M118 x 3.55	1
110	BV0409	Rotor Cap	1
111	BM1212540	Bolt- M12 x 1.25 x 40	4
112	OP12125	Oil Plug- M12 x 1.5	1
113A	CX0113A	Tailgate Extension- Left	1
113B	CX0113B	Tailgate Extension- Right	1
114	CX0601-086	Tailgate- CXT-086	1
	CX0601-095	Tailgate- CXT-095	1
	CX0601-104	Tailgate- CXT-104	1
	CX0601-112	Tailgate- CXT-112	1
	CX0601-121	Tailgate- CXT-121	1
115	BV0601	Rod- Tailgate	4
116	LNM2430	Self-Locking Nut- M24 x 3	4
117	FW24	Washer- M24	4
118	BV0601	Upper Spring- Tailgate	4
119	BV0606	Spacer- Tailgate	4
120	BV0602	Lower Spring- Tailgate	4
121	BM141545	Bolt- M14 x 1.5 x 45	12
122	BV0603	Bracket- Tailgate Spring	8
123	BV0604	Bolt Spacer- Tailgate	4
124	BM1012545	Bolt- M10 x 1.25 x 45	4
125	CXTCFS	Fan Shroud	1
126	CXTCF-01	Fan	1
127	BM061016	Securing Bolt- Fan	1
128	CXTCF-02	Fan Protection Screen	1
129	BM061016	Bolt- M6 x 1.0 x 16	4

PTO Shaft

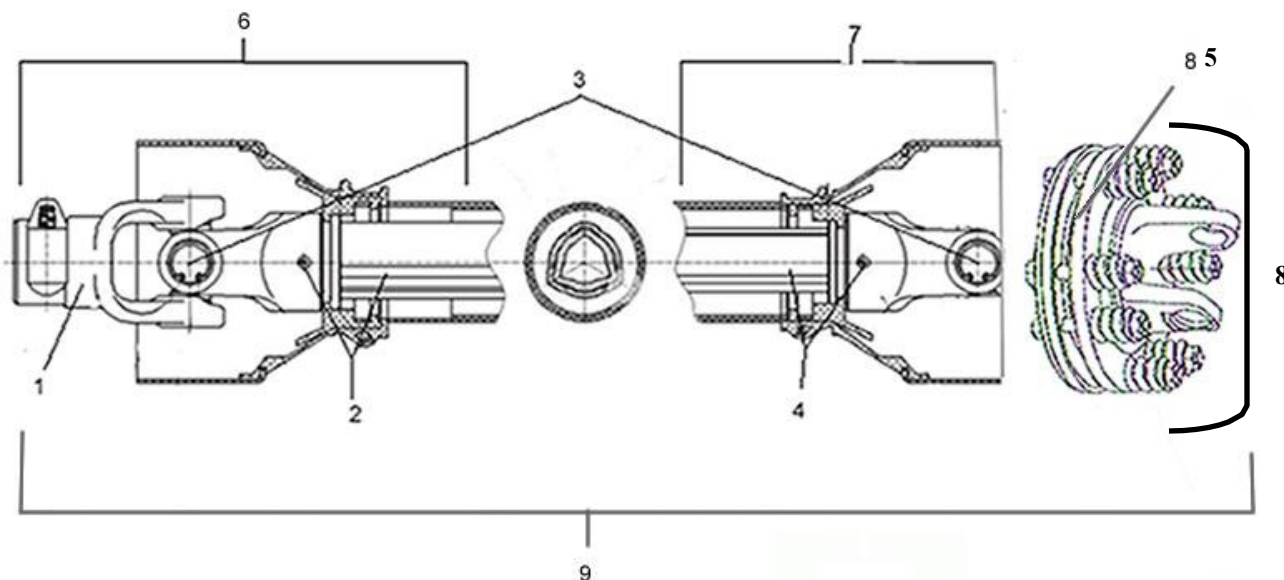

Pos.	Part #	Description	Qty
1	DP1075-60 DP1075-80	PTO Yoke - Series 60 PTO Yoke—Series 80	1
2	DP1079-60 DP1079-80	Female Yoke and Tube (tractor end) - Series 60 Female Yoke and Tube (tractor end) - Series 80	1
3	DP1076-60 DP1076-80	Cross and Bearings - Series 60 Cross and Bearings - Series 80	2
4	DP1078-60 DP1078-80	Male Yoke and Tube (implement end) - Series 60 Male Yoke and Tube (implement end) - Series 80	1
5	180-510-60 180-510-80	Friction Disc - 150mm x 93mm (RXT) Friction Disc - 160mm x 98mm (BXV / CXT)	4
6	DP1074F-60 DP1074F-80	Complete Female End PTO Shielding (tractor end) - Series 60 Complete Female End PTO Shielding (tractor end) - Series 80	1
7	DP1074M-60 DP1074M-80	Complete Male End PTO Shielding (implement end) - Series 60 Complete Male End PTO Shielding (implement end) - Series 80	1
8	DP1098-60 DP1098-80	Slip Clutch Complete - 200 mm Clutch (4 disc) for Series 60 Slip Clutch Complete - 200 mm Clutch (4 disc) for Series 80	1
9	147125 147130	Complete PTO - Series 60 - 200mm Slip Clutch (RXT) Complete PTO - Series 80 - 200mm Slip Clutch (BXV & CXT)	1

VERSION 1

MODEL #	SERIAL #'s
CXT-076	UP TO 5004
CXT-086	UP TO 20002
CXT-095	UP TO 23003
CXT-104	UP TO 26001
CXT-112	UP TO 28001
CXT-121	UP TO 30005

VERSION 2

MODEL #	SERIAL #'s
CXT-076	5005 & AFTER
CXT-086	20003 & AFTER
CST-095	23004 & AFTER
CXT-104	26002 & AFTER
CXT-112	28002 & AFTER
CXT-121	30006 & AFTER

LIMITED WARRANTY

Belco Resources Equipment warrants to the original purchaser of any new piece of machinery from Belco Resources Equipment, purchased from an authorized Belco Resources Equipment dealer, that the equipment be free from defects in material and workmanship for a period of one (1) year for non-commercial, state, and municipalities' use, ninety (90) days for commercial use from date of retail sale. Warranty for rental purposes is thirty (30) days. The obligation of Belco Resources Equipment to the purchaser under this warranty is limited to the repair or replacement of defective parts.

A four (4) year extended **Gearbox Limited Warranty** is provided for YCT, RXT AND CXT models at the end of the standard one (1) year warranty period. This warranty is not provided for commercial or rental uses. The extended warranty provides for the replacement of parts only. Not covered are oil seals or any damages to the gearbox due to lack of lubrications.

Replacement or repair parts installed in the equipment covered by this limited warranty are warranted for ninety (90) days from the date of purchase of such part or to the expiration of the applicable new equipment warranty period, whichever occurs later. Warranted parts shall be provided at no cost to the user at an authorized Belco Resources Equipment dealer during regular working hours. Belco Resources Equipment reserves the right to inspect any equipment or parts which are claimed to have been defective in material or workmanship.

This limited warranty does not apply to and excludes wear items such as shear pins, tires, tubes knives, blades or other wear items. Oil or grease is not covered by this warranty.

All obligations of Belco Resources Equipment under this limited warranty shall be terminated if:

Proper service is not preformed on the machine

The machine is modified or altered in any way.

The machine is being used or has been used for purposes other than those for which the machine was intended.

DISCLAIMER OF IMPLIED WARRANTIES & CONSEQUENTIAL DAMAGES

Belco Resources Equipment obligation under this limited warranty, to the extent allowed by law, is in lieu of all warranties, implied or expressed, including implied warranties of merchantability and fitness for a particular purpose and any liability for incidental and consequential damages with respect to the sale or use of the items warranted. Such incidental and consequential damages shall include but not be limited to: transportation charges other than normal freight charges; cost of installation other than cost approved by Belco Resources Equipment; duty; taxes; charges for normal service or adjustment; loss of crops or any other loss of income; rental of substitute equipment, expenses due to loss, damage, detention or delay in the delivery.



BELC 
RESOURCES
EQUIPMENT

Increasing agricultural productivity since 1974

401 Jeffreys Road
Rocky Mount, NC 27804
[Www.BR-Equipment.com](http://www.BR-Equipment.com)

Tel: 252-442-0700
Fax: 252-787-5855
Sales@BRGlimited.com